



# AIRTRONIC\* / AIRTRONIC\* M

**Technical description**  
**Installation instructions**  
**Operating instructions**  
**Maintenance instructions**

**Eberspächer**

J. Eberspächer  
GmbH & Co. KG  
Eberspächerstr. 24  
D - 73730 Esslingen

Telefon (zentral)  
(0711) 939 - 00  
Telefax  
(0711) 939 - 0500

[www.eberspaecher.com](http://www.eberspaecher.com)

## **Air heaters for diesel fuel AIRTRONIC / AIRTRONIC M, operating independently of the engine**

Heater	Order no.
AIRTRONIC – D2, 12 V	25 2069 05 00 00
AIRTRONIC – D2, 12 V as complete package	25 2115 05 00 00
AIRTRONIC – D2, 24 V	25 2070 05 00 00
AIRTRONIC – D2, 24 V as complete package	25 2116 05 00 00
AIRTRONIC – D2 Camper, 12 V	25 2326 05 00 00
AIRTRONIC M – D4, 12 V	25 2113 05 00 00
AIRTRONIC M – D4, 24 V	25 2114 05 00 00
AIRTRONIC M – D4S, 12 V	25 2144 05 00 00
AIRTRONIC M – D4S, 24 V	25 2145 05 00 00
AIRTRONIC M – D3 Camper, 12 V	25 2317 05 00 00
AIRTRONIC M – D4 Camper, 12 V	25 2318 05 00 00
AIRTRONIC M – D4 Camper plus, 12 V	25 2327 05 00 00

## **Air heaters for petrol fuel AIRTRONIC M, operating independently of the engine**

Heater	Order no.
AIRTRONIC M – B4, 12 V	20 1812 05 00 00



**Please give this manual to the customer  
after installation of the heater.**

# 1 Introduction

## Contents

Chapter	Title	Contents	Page
1	<b>Introduction</b>	<ul style="list-style-type: none"> <li>• Contents ..... 2</li> <li>• Concept of this manual ..... 3</li> <li>• Special text structure, presentation and picture symbols ..... 4</li> <li>• Important information before starting work ..... 4</li> <li>• Statutory regulations ..... 5, 6</li> <li>• Safety instructions for installation and operation ..... 6, 7</li> <li>• Accident prevention ..... 7</li> </ul>	
2	<b>Product information</b>	<ul style="list-style-type: none"> <li>• Scope of supply <i>AIRTRONIC</i> / <i>AIRTRONIC</i> M ..... 8, 9</li> <li>• Scope of supply <i>AIRTRONIC</i> M / <i>AIRTRONIC</i> M (Camper heater) .... 10, 11</li> <li>• Technical data <i>AIRTRONIC</i> for diesel ..... 12</li> <li>• Technical data <i>AIRTRONIC</i> M for diesel ..... 13</li> <li>• Technical data <i>AIRTRONIC</i> M for petrol ..... 14</li> <li>• Main dimensions ..... 15</li> </ul>	
3	<b>Installation</b>	<ul style="list-style-type: none"> <li>• Installation and location ..... 16</li> <li>• Installing the 24 V heater in a vehicle for the transport of dangerous goods ..... 17</li> <li>• Installation location ..... 16, 17</li> <li>• Possible installation positions ..... 18</li> <li>• Cable harness connection, right or left ..... 18</li> <li>• Mounting and fastening ..... 19</li> <li>• Nameplate ..... 20</li> <li>• Heater air system ..... 21</li> <li>• Exhaust system ..... 22</li> <li>• Combustion air system ..... 23</li> <li>• Fuel supply ..... 24 – 28</li> </ul>	
4	<b>Operation and function</b>	<ul style="list-style-type: none"> <li>• Operating instructions/ important information for operation ..... 29</li> <li>• Initial commissioning ..... 29</li> <li>• Description of functions ..... 30</li> <li>• Control and safety devices / EMERGENCY OFF ..... 31</li> </ul>	
5	<b>Electrical system</b>	<ul style="list-style-type: none"> <li>• Heater wiring ..... 32</li> <li>• Parts list for the circuit diagrams ..... 32, 33</li> <li>• Circuit diagrams at the end of this manual</li> </ul>	
6	<b>Troubleshooting Maintenance Service</b>	<ul style="list-style-type: none"> <li>• In case of faults, please check the following points ..... 34</li> <li>• Troubleshooting ..... 34</li> <li>• Maintenance instructions ..... 34</li> <li>• Service ..... 34</li> </ul>	
7	<b>Environment</b>	<ul style="list-style-type: none"> <li>• Certification ..... 35</li> <li>• Disposal ..... 35</li> <li>• EU Declaration of Conformity ..... 35</li> </ul>	
8	<b>Lists</b>	<ul style="list-style-type: none"> <li>• List of key words ..... 36, 37</li> <li>• List of abbreviations ..... 37</li> </ul>	



# 1 Introduction

---

## Concept of this manual

This manual aims to support the service company installing the heater and to provide the user with all important information about the heater. The manual has been divided into 8 chapters to make it easier to find the corresponding information quickly.

1

### Introduction

Here you will find important introductory information about installation of the heater and about the structure of the manual.

5

### Electric system

Here you will find information about the electronic system and electronic components of the heater.

2

### Product information

Here you will find information about the scope of supply, the technical data and the dimensions of the heater.

6

### Troubleshooting / maintenance / service

This section contains information on possible faults and malfunctions, troubleshooting, maintenance and the service hotline.

3

### Installation

Here you will find important information and instructions referring to installation of the heater.

7

### Environment

Here you will find information about certification and disposal of the heater together with the EU Declaration of Conformity.

4

### Operation and function

Here you will find information about the operation and function of the heater.

8

### Lists

Here you will find the key word list and abbreviations list.

# 1 Introduction

## Special text structure, presentation and picture symbols

This manual uses special text structures and picture symbols to emphasise different contents. Please refer to the examples below for the corresponding meanings and associated actions.

### Special structure and presentations

A dot (•) indicates a list which is started by a heading. If an indented dash (–) follows a dot, this list is subordinate to the dot.

### Picture symbols

#### Regulation!

This picture symbol with the remark "Regulation" refers to a statutory regulation. Failure to comply with this regulation results in expiry of the type permit for the heater and preclusion of any guarantee and liability claims on J. Eberspächer GmbH & Co. KG.

#### Danger!

This picture symbol with the remark "Danger!" refers to the risk of a fatal danger to life and limb. Failure to comply with these instructions can result in severe injuries under certain circumstances.

#### Caution!

This picture symbol with the remark "Caution!" refers to a dangerous situation for a person and / or the product. Failure to comply with these instructions can result in injuries to people and/or damage to machinery.

#### **Please note!**

These remarks contain application recommendations and useful tips for installation of the heater.

## Important information before starting work

### Range of application of the heater

The water heater operating independently of an engine is intended for installation in the following vehicles, depending on its heating output:

- Vehicles of all kinds (max 9 seats)
- Construction machinery
- Agricultural machinery
- Boats, ships and yachts (only diesel heaters)
- Camper vans

#### **Please note!**

- The camper heaters are intended for installation in camper vans. Version D3-Camper should be used in situations requiring reduced noise levels.
- The heaters (only diesel heaters, 24 volt) can be installed in vehicles used for the transport of dangerous goods as per ADR / ADR99.
- The current controller is to be replaced by a special controller when the heater is to be used to heat the freight compartment / cargo (order no. see heater price list or spare parts list).

### Purpose of the heater (using the vehicle heat exchanger)

- Pre-heating, de-misting windows
- Heating and keeping the following warm:
  - Driver and working cabs, Ship's cabins
  - Freight compartments
  - Passenger and crew compartments
  - Vehicle engines and units
  - Camper vans

On account of its functional purpose, the heater is not permitted for the following applications:

- Long-term continuous operation, e.g. for preheating and heating of:
  - Residential rooms
  - Garages
  - Work huts, weekend homes and hunting huts
  - Houseboats, etc.
- Heating or drying
  - Living creatures (people or animals) by blowing hot air directly at the subject
  - Objects
  - Blowing hot air into containers

#### Caution! **Safety instructions for application and proper purpose**





- The heater must only be used and operated for the range of application stated by the manufacturer in compliance with the "Operating instructions" included with every heater.



# 1 Introduction

## Statutory regulations

The Federal Road Transport Directorate has issued an "EC type approval" and an "EMC type approval" for the heater for installation in motor vehicles and with the following official type approval marks, noted on the heater name plate.

AIRTRONIC	EC-  01 00 0025
	EMC-  02 1516
AIRTRONIC M	EC-  01 00 0026
	EMC-  02 1653



### Regulation!

#### Directive 2001 / 56 / EU of the European Parliament and the Council

##### • Arrangement of the heater

- Parts of the structure and other components near the heater must be protected from excess heat exposure and possible contamination from fuel or oil.
- The heater must not pose a fire hazard even when it overheats.  
This requirement is deemed to be fulfilled when adequate clearance to all parts is observed during installation, sufficient ventilation is provided and fire-proof materials or heat plates are used.
- The heater must not be mounted in the passenger compartment of vehicles in class M<sub>2</sub> and M<sub>3</sub>. But a heater in a hermetically sealed enclosure which otherwise complies with the conditions stated above may be used.
- The factory nameplate or duplicate must be affixed so that it can still be easily read when the heater is installed in the vehicle.
- All appropriate precautions must be taken when arranging the heater to minimise the risk of injuries to persons or damage to other property.

##### • Operating status display

- A clearly visible operating display in the user's field of vision must indicate when the heater is switched on and off.

##### • Fuel supply

- The fuel intake connection must not be located in the passenger compartment and must be sealed with a properly closing lid to prevent any fuel leaks.
- In heaters for liquid fuel where the heater fuel is separate from the vehicle fuel, the type of fuel and intake connection must be clearly identified.
- A warning sign is to be fixed to the intake connection indicating that the heater must be switched off before refuelling.

##### • Exhaust system

- The exhaust outlet must be arranged so as to prevent any penetration of exhaust fumes into the vehicle interior through the ventilation system, warm air intakes or open windows.

##### • Combustion air intake

- The air for the heater combustion chamber must not be sucked in from the passenger compartment of the vehicle.
- The air intake must be arranged or protected in such a way that it cannot be blocked by other objects.

##### • Heater air intake

- The heater air supply must consist of fresh air or circulated air and be sucked in from a clean area not contaminated by exhaust fumes of the drive machine, the combustion heater or any other source in the vehicle.
- The intake pipe must be protected by a grid or other suitable means.

##### • Hot air outlet

- The hot air pipes within the vehicle must be arranged or protected in such a way that there is no risk of injury or damage if they are touched.
- The air outlet must be arranged or protected in such a way that it cannot be blocked by any objects.

# 1 Introduction

## Statutory regulations

### § Regulation!

#### Mounting the heater in a vehicle for the transport of dangerous goods as per ADR / ADR99

- When the heater is to be installed in vehicles for the transport of dangerous goods, the regulations of ADR / ADR99 must also be observed.

### Please note!

- Compliance with the statutory regulations and safety instructions is prerequisite for guarantee and liability claims.  
Failure to comply with the statutory regulations and safety instructions and incorrect repairs even when using original spare parts make the guarantee null and void and preclude any liability for J. Eberspächer GmbH & Co. KG.
- Detailed information about the regulations of ADR / ADR99 are contained in the information leaflet no. 25 2161 95 15 80 (see also page 16 and 31).
- Subsequent installation of this heater must comply with these installation instructions.
- The statutory regulations are binding and must also be observed in countries which do not have any special regulations.
- When the heater is to be installed in vehicles not subject to the German Ordinance for the Registration of Motor Vehicles (StVZO), for example ships, the specially valid regulations and installation instructions for these special applications must be observed.
- Installation of the heater in special vehicles must comply with the regulations applying to such vehicles.
- Other installation requirements are contained in the corresponding sections of this manual.

## Safety instructions for installation and operation



### Danger!

#### Risk of injury, fire and poisoning!

- The heater must only be started up when the maintenance flap is closed and the outlet hood is mounted in position.
- The maintenance flap must not be opened during operation.
- Disconnect the vehicle battery before commencing any kind of work.
- Before working on the heater, switch the heater off and let all hot parts cool down.
- The heater must not be operated in closed rooms, e.g. in the garage or in a multi-storey car park.
- Adjustable hot air outlets must always be adjusted so that they cannot blow hot air directly at living creatures (people, animals) or objects sensitive to temperature (loose and/or fastened).



### Caution!

#### Safety instructions for installation and operation!

- The year of initial commissioning must be marked on the nameplate.
- The heat exchanger of air heaters is a component subject to high thermal loads which must be replaced 10 years after initial commissioning of the heater. In addition, the installation date must be entered on the plate "original spare part" enclosed with the heat exchanger must. Then affix the plate next to the nameplate on the heater.
- The heater must only be installed by a JE partner authorised by the manufacturer according to the instructions in this manual and possibly according to special installation recommendations; the same applies to any repairs to be carried out in the case of repairs or guarantee claims.
- Only the control elements approved by Eberspächer must be used to operate the heater. The use of other control elements can cause malfunctions.



# 1 Introduction

## Safety instructions for installation and operation



### Caution!

#### Safety instructions for installation and operation!

- Repairs by unauthorised third-parties or with not original spare parts are dangerous and therefore not allowed. They result in expiry of the type permit of the heater; consequently, when installed in motor vehicles they can cause expiry of the vehicle operating licence.
- The following measures are not allowed:
  - Changes to components relevant to the heater.
  - Use of third-party components not approved by Eberspächer.
  - Nonconformities in installation or operation from the statutory regulations, safety instructions or specifications relevant to safe operation as stated in the installation instructions and operating instructions. This applies in particular to the electrical wiring, fuel supply, combustion air system and exhaust system.
- Only original accessories and original spare parts must be used during installation or repairs.
- When carrying out electric welding on the vehicle, the plus pole cable at the battery should be disconnected and placed at ground to protect the controller.
- The heater must not be operated where there is a risk of an accumulation of flammable vapours or dust, for example close to
  - fuel depot
  - coal depot
  - wood depot
  - grain depots etc.
- The heater must be switched off when refuelling.
- When the heater is mounted in a safety housing etc., the installation compartment of the heater is not a stowage compartment and must be kept clear. In particular fuel canisters, oil cans, spray cans, gas cartridges, fire extinguishers, cleaning rags, items of clothing, paper etc. must not be stored or transported on or next to the heater.
- Defect fuses must only be replaced by fuses with the prescribed rating.
- If fuel leaks from the heater fuel system, arrange for the damage to be repaired immediately by a JE service partner.
- After-running of the heater must not be interrupted prematurely e.g. by pressing the battery disconnecting switch, apart from in the case of an emergency stop.

## Accident prevention

General accident prevention regulations and the corresponding workshop and operation safety instructions are to be observed.

## 2 Product information

### Scope of supply for AIRTRONIC

Quantity / Designation	Order number
1 D 2 – 12 V	25 2069 05 00 00
1 D 2 – 24 V	25 2070 05 00 00

To be ordered separately:

1 Universal installation kit	25 2069 80 00 00
1 Control unit*	----

or

1 D 2 – 12 V as complete package**	25 2115 05 00 00
1 D 2 – 24 V as complete package**	25 2116 05 00 00

To be ordered separately:

1 Control unit*	----
-----------------	------

### Scope of supply for AIRTRONIC M

Quantity / Designation	Order number
1 B 4 – 12 V	20 1812 05 00 00
1 D 4 – 12 V	25 2113 05 00 00
1 D 4 – 24 V	25 2114 05 00 00

To be ordered separately:

1 Universal installation kit	25 2113 80 00 00
1 Control unit*	----

1 D 4 S – 12 V	25 2144 05 00 00
1 D 4 S – 24 V	25 2145 05 00 00

To be ordered separately:

1 Universal installation kit	25 2144 80 00 00
1 Control unit*	----

\* Control units see price list / accessories catalogue.

\*\* Complete package contains:  
1 Heater  
1 Universal installation kit

### Parts list for the picture “Scope of supply” on page 9

#### Scope of supply for heater

##### Pict.-No. Designation

1	Heater
2	Dosing pump

#### Scope of supply for universal installation kit

##### Pict.-No. Designation

3	Exhaust silencer
4	Cable tree, heater
5	Cable harness, plus / minus
6	Cable harness, controls
7	Flexible exhaust pipe
8	Combustion air hose
9	Cable tie
10	Bracket, dosing pump
11	Pipe, 6 x 2
12	Pipe, 4 x 1
13	Hose, 5 x 3
14	Outlets, rotating
15	Grid
16	Hood
17	Flexible pipe
18	Hose clip

#### Please note!

- Parts without picture number are small parts and packed in a bag.
- Please consult the additional parts catalogue if any other parts are required for installation.





## 2 Product information

### Scope of supply for AIRTRONIC and AIRTRONIC M

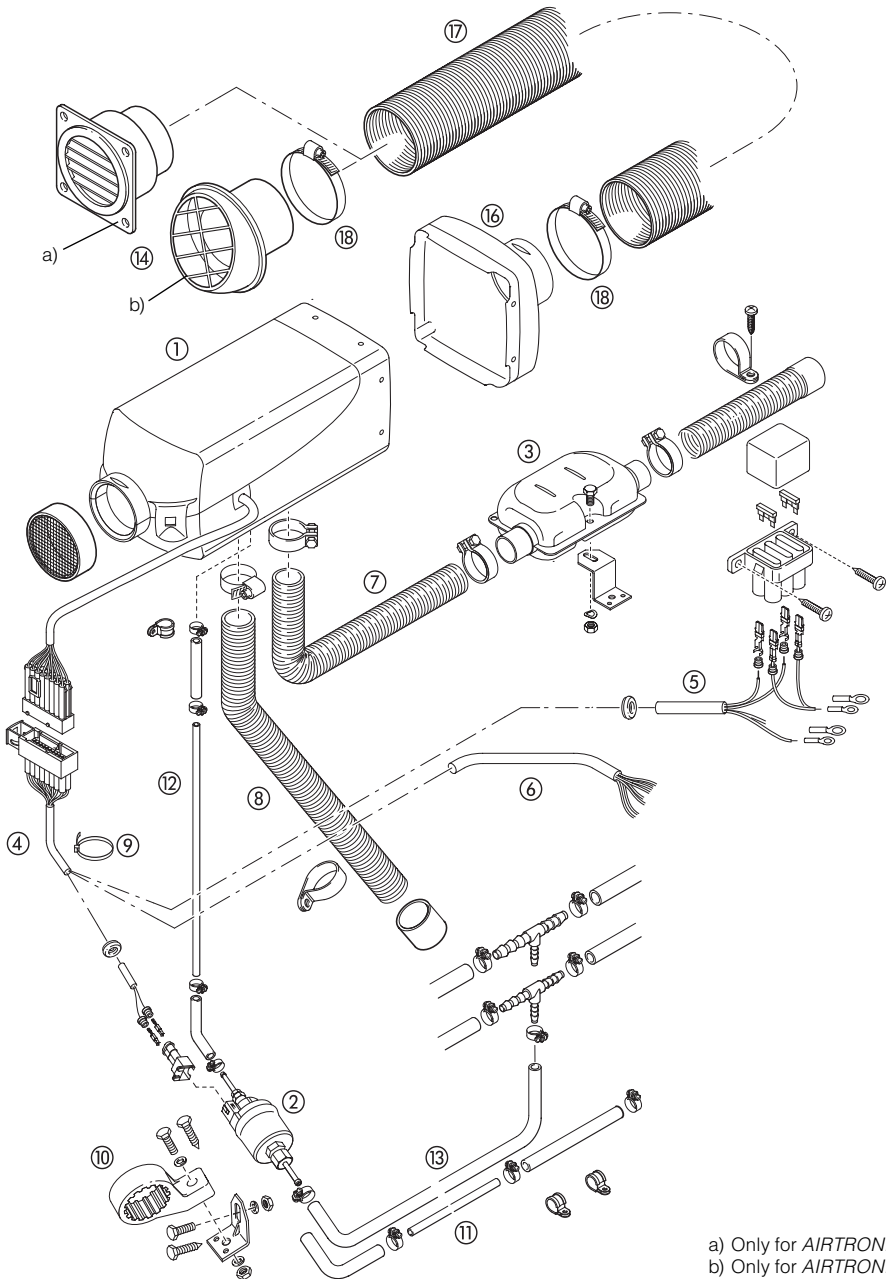

a) Only for AIRTRONIC  
b) Only for AIRTRONIC

EN

FR

## 2 Product information

### Scope of supply for *AIRTRONIC* (Camper-heater)

Quantity / Designation	Order number
1 D 2 Camper – 12 V	25 2326 05 00 00
To be ordered separately:	
1 Installation kit	25 2326 80 00 00
1 Control unit	----

### Scope of supply for *AIRTRONIC M* (Camper-heater)

Quantity / Designation	Order number
1 D 3 Camper – 12 V	25 2317 05 00 00
1 D 4 Camper – 12 V	25 2318 05 00 00
To be ordered separately:	
1 Installation kit	25 2318 80 00 00
1 Control unit	----
1 D 4 Camper plus – 12 V	25 2327 05 00 00
To be ordered separately:	
1 Installation kit	25 2327 80 00 00
1 Control unit	----

### Parts list for the picture “Scope of supply” on page 11

#### Scope of supply for heater

##### Pict.-No. Designation

1	Heater
2	Dosing pump

#### Scope of supply for universal installation kit

Pict.-No.	Designation
3	Combustion air intake silencer
4	Exhaust silencer
5	Hose fitting
6	Grating
7	Y-branch
8	Kit tank connection
9	Temperature sensor
10	Cable harness for temperature sensor
11	Mini timer
12	Mini controller
13	Lead harness plus/minus
14	Lead harness control
15	Hose clip
16	Hose clip
17	Pipe, 4 x 1.25
18	Cable harness heater
19	Flexible exhaust pipe
20	Grating
21	Bracket dosing pump
22	Cable tape
23	Hood
24	Outflow

\* Flexible pipe not included in the scope of supply. For order number and dimensions, see Accessories Catalogue.

#### Please note!

- Parts without picture number are small parts and packed in a bag.
- Please consult the additional parts catalogue if any other parts are required for installation.



## 2 Product information

### Scope of supply for AIRTRONIC and AIRTRONIC M (Camper-heater)

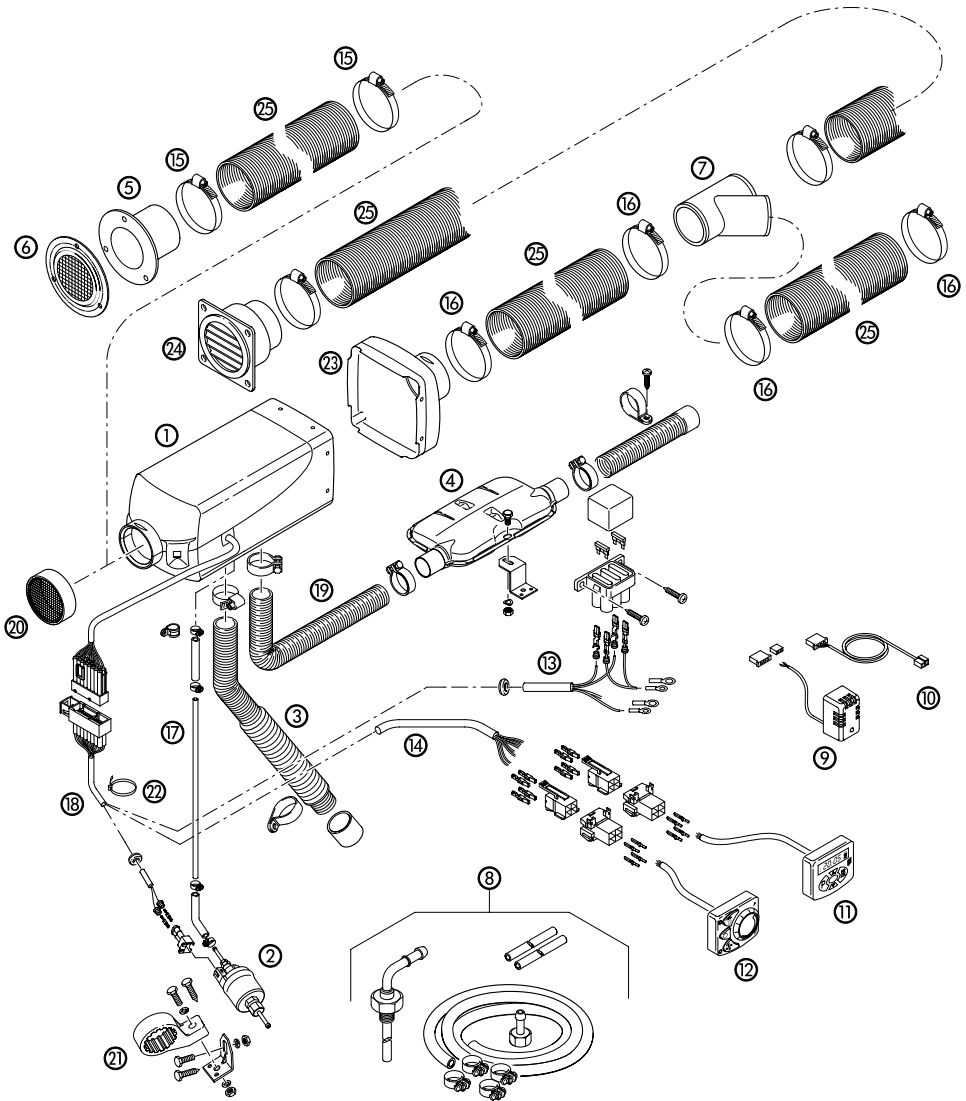

## 2 Product information

Technical data / Heater		AIRTRONIC for diesel			
Version		D2 / D2 Camper			
Heating medium		Air			
Control of the heat flow		Stage			
		Power	Large	Medium	Small
Heat flow (watt)		2200	1800	1200	850
Heater air flow rate without counterpressure (kg/h)		105	90	60	40
Heater code		6 for outlet hood Ø 60 mm			
		12 for outlet hood Ø 75 mm			
Fuel consumption (l/h)		0.28	0.23	0.15	0.10
Elektr. power (watt)					
in operation (12 and 24 volt)		34	22	12	8
at Start (12 and 24 volt)		<100			
in the control phase „OFF“		4 to 5			
Rated voltage		12 or 24 Volt			
Operating range					
Lower voltage limit: An undervoltage protection in the controller switches the heater off on reaching approx. 10.5 volt resp. 21 volt.		approx. 10.5 volt resp. 21 volt Undervoltage protection trigger time: 20 seconds			
Upper voltage limit: An overvoltage protection in the controller switches the heater off on reaching approx. 16 volt resp. 32 volt.		approx. 16 volt resp. 32 volt Overvoltage protection trigger time: 20 seconds			
Fuel „Fuel quality“ and „Fuel at low temperatures“ see page 28.		Commercially available diesel fuel (DIN EN 590)			
Tolerable operating temperature		Operation			
		Storage			
Operation		-40 °C to +70 °C			
Storage		-40 °C to +85 °C			
Noise emission – passenger compartment		The maximum noise pressure level is <60 db (A), measured in the operating mode power stage „Large“, as per 3.GSGV resp. DIN 45 635, part 1.			
Maximum air intake temperature		+40 °C			
Interference suppression		Interference suppression class 5 to DIN EN 55 025 for VHF, HF, MW Interference suppression class 4 to DIN EN 55 025 for LW			
Weight		approx. 2.7 kg			



**Caution!**

### Safety instructions for technical data!

Failure to comply with the technical data can result in malfunctions.

All technical data ±10%



## 2 Product information

Technical data / Heater		AIRTRONIC M for diesel			
Version		D3 Camper / D4 / D4S / D4 Camper / D4 Camper plus			
Heating medium		Air			
Control of the heat flow		Stage			
		Power	Large	Medium	Small
Heat flow (watt)	D3 Camper	3000	2200	1600	900
	D4 / D4S	4000 / 3500	3000	2000	1000
	D4 Camper / D4 Camper plus	4000 / 3500	3000	2000	900
Heater air flow rate without counterpressure (kg/h)	D3 Camper	150	120	90	60
	D4 / D4S	185 / 160	150 / 140	110 / 100	65 / 60
	D4 Camper / D4 Camper plus	185 / 160	150 / 140	110 / 100	60 / 55
Heater code	D3 Camper / D4 / D4 Camper	3 for outlet hood Ø 75 mm			
	D3 Camper / D4 / D4 Camper	10 for outlet hood Ø 90 mm			
	D4S / D4 Camper plus	10 for outlet hood Ø 75 mm			
Fuel consumption (l/h)	D3 Camper	0.38	0.28	0.2	0.11
	D4 / D4S	0.51 / 0.44	0.38 / 0.38	0.25 / 0.25	0.13 / 0.13
	D4 Camper / D4 Camper plus	0.51 / 0.44	0.38 / 0.38	0.25 / 0.25	0.11 / 0.11
Elektr. power (watt) in operation (12 and 24 volt)	D3 Camper	24	16	10	7
	D4 / D4 S	40 / 40	24 / 30	13 / 16	7 / 8
	D4 Camper / D4 Camper plus	40 / 40	24 / 30	13 / 16	7 / 8
at Start (12 and 24 volt)		<100			
in the control phase „OFF“		4 to 5			
Rated voltage		12 or 24 volt			
Operating range Lower voltage limit: An undervoltage protection in the controller switches the heater off on reaching approx. 10.5 volt resp. 21 volt.		approx. 10.5 volt resp. 21 volt Undervoltage protection trigger time: 20 seconds			
Upper voltage limit: An overvoltage protection in the controller switches the heater off on reaching approx. 16 volt resp. 32 volt.		approx. 16 volt resp. 32 volt Overvoltage protection trigger time: 20 seconds			
Fuel „Fuel quality“ and „Fuel at low temperatures“ see page 28.		Commercially available diesel fuel (DIN EN 590)			
Tolarable operating temperature	Operation	-40 °C to +70 °C			
	Storage	-40 °C to +85 °C			
Noise emission – passenger compartment		The maximum noise pressure level is <60 db (A), measured in the operating mode power stage „Large“, as per 3.GSGV resp. DIN 45 635, part 1.			
Maximum air intake temperature		+40 °C			
Interference suppression		Interference suppression class 5 to DIN EN 55 025 for VHF, HF, MW Interference suppression class 4 to DIN EN 55 025 for LW			
Weight		approx. 4.5 kg			

## 2 Product information

Technical data / Heater	AIRTRONIC M für Benzinkraftstoff				
Version	B4				
Heating medium	Air				
Control of the heat flow	Stage				
	Power	Large	Medium	Small	
Heat flow (watt)	3800	3200	2100	1300	
Heater air flow rate without counterpressure (kg/h)	185	160	120	85	
Heater code	3 for outlet hood Ø 75 mm				
Fuel consumption (l/h)	0,54	0,46	0,29	0,18	
Elektr. power (watt)	40	29	15	9	
					in operation (12 and 24 volt)
					at Start (12 and 24 volt)
in the control phase „OFF“	4 to 5				
Rated voltage	12 volt				
Operating range Lower voltage limit: An undervoltage protection in the controller switches the heater off on reaching approx. 10.5 volt.	approx. 10.5 volt Undervoltage protection trigger time: 20 seconds				
	Upper voltage limit: An overvoltage protection in the controller switches the heater off on reaching approx. 16 volt.	approx. 16 volt Undervoltage protection trigger time: 20 seconds			
Fuel „Fuel quality“ and „Fuel at low temperatures“ see page 28.		Commercially available petrol fuel (DIN EN 228)			
Tolerable operating temperature	Operation heater	-40 °C to +50 °C			
	Storage heater	-40 °C to +85 °C			
	Operation dosing pump	-40 °C to +20 °C			
	Storage dosing pump	-40 °C to +125 °C			
Noise emission – passenger compartment	The maximum noise pressure level is <60 db (A), measured in the operating mode power stage „Large“, as per 3.GSGV resp. DIN 45 635, part 1.				
Maximum air intake temperature	+40 °C				
Interference suppression	Interference suppression class 5 to DIN EN 55 025 for VHF, HF, MW Interference suppression class 4 to DIN EN 55 025 for LW				
Weight	approx. 4.5 kg				



### Caution!

#### Safety instructions for technical data!

Failure to comply with the technical data can result in malfunctions.

All technical data ±10%

## 2 Product information

### Main dimensions AIRTRONIC

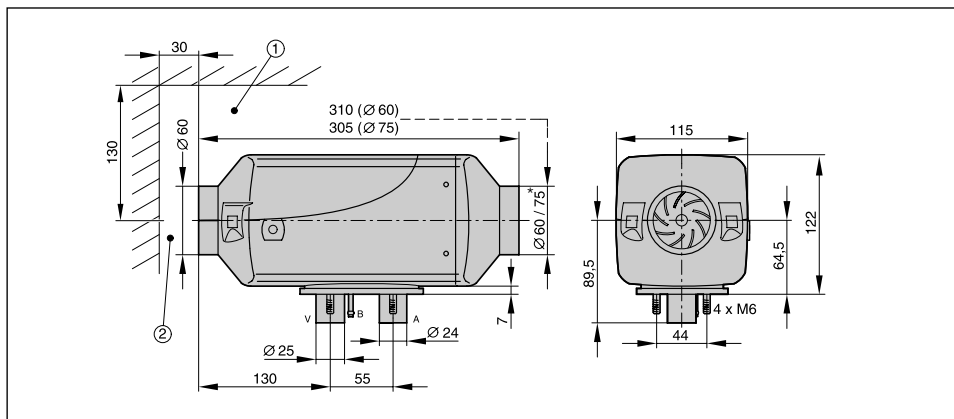

### Main dimensions AIRTRONIC M

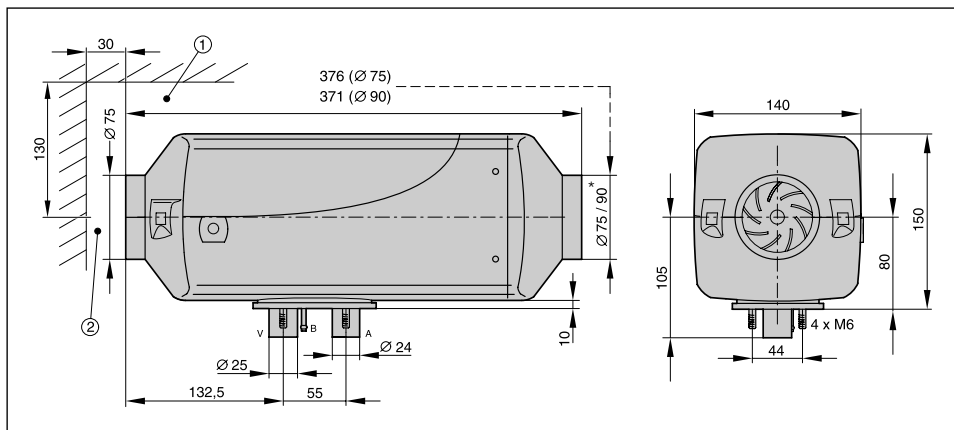

- ① Minimum installation clearance (space) for opening the lid and for dismantling the glow plug and the controller.  
 ② Minimum installation clearance (space) for intake of heater air.

A = Exhaust  
 B = Fuel  
 V = Combustion air

\* Outflow hood for AIRTRONIC – D2, D2 Camper:

- Ø 60 mm, included in scope of supply
- Ø 75 mm, available as extra part

Outflow hood for AIRTRONIC – M B4, D4, D3 Camper, D4 Camper:

- Ø 90 mm, included in scope of supply
- Ø 75 mm, available as extra part

Outflow hood for AIRTRONIC – M D4S, D4 Camper plus:

- Ø 75 mm, included in scope of supply
- (outflow hood Ø 90 mm not allowed)

## 3 Installation

### Installation and location

The heater is suitable and certified for installation in parts of vehicles used by persons.  
Installation in the cab or passenger compartments of coaches or buses with more than 9 seats is not allowed.

When installing in compartments used by persons, the exhaust, combustion air and fuel pipes in these areas must not have any detachable connections and must be routed splash-waterproof in the breakthroughs. For this reason, the heater can be mounted with its foot using the flange seal in the foot to the vehicle floor or to an outer wall of the vehicle.

The electronic control is integrated in the heater which makes wiring during installation much easier.

#### Please note!

- When installing the heater, always make sure there is sufficient clearance left for intake of the heater air and for dismantling the glow plug and controller.
- The regulations and safety instructions to be observed for this chapter are on page 4 – 7.

### Installation position

#### Installation position in a camper van

In a camper van, the heater is preferably installed in the inner compartment or luggage compartment.  
If it cannot be installed in the inner compartment or luggage compartment, the heater can also be fitted to the vehicle floor from underneath.

#### Please note!

Heaters D2 Camper, D3 Camper, D4 Camper and D4 Camper plus are intended for installation in a camper van.

### Installing the diesel heater 24 V in a vehicle for the transport of dangerous goods as per ADR / ADR99

The 24 Volt diesel heater can be installed in vehicles used for the transport of dangerous goods as per ADR / ADR99.

The heater fulfils the regulations of ADR / ADR99 with the corresponding electrical wiring, see circuit diagrams at the end of this manual.

Detailed information about the ADR / ADR99 regulations is contained in leaflet no. 25 2161 95 15 80.

#### Please note!

For installation of the heater in vehicles for the transport of dangerous goods, the regulations of ADR / ADR99 must be observed.

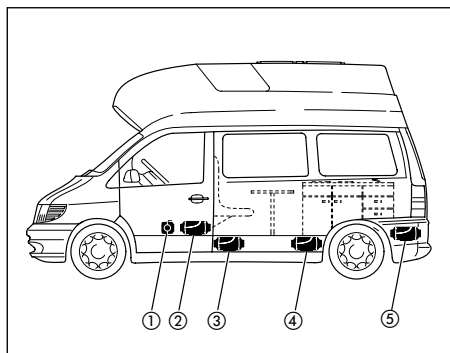

- ① Heater in front of the passenger seat
- ② Heater between the driver's seat and the passenger seat
- ③ Heater under the vehicle floor
- ④ Heater under the back seat
- ⑤ Heater in the boot



### 3 Installation

#### Installation

##### Installation in a car or people carrier

In a car or people carrier, the heater is preferably installed in the passenger compartment or boot. If it is not possible to install the heater in the passenger compartment or boot, the heater can also be mounted under the vehicle floor.

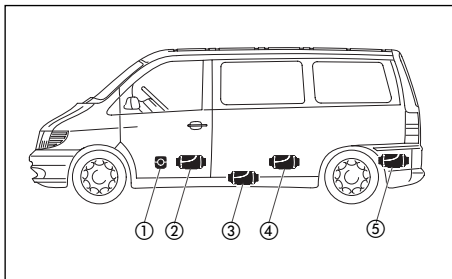

- ① Heater in front of the passenger seat
- ② Heater between the driver's seat and the passenger seat
- ③ Heater under the vehicle floor
- ④ Heater under the back seat
- ⑤ Heater in the boot

##### Installation in an excavator cab (only diesel heaters)

In an excavator, the heater is preferably installed in the cab. If it is not possible to install the heater in the cab, the heater can also be installed in a storage box outside the cab.

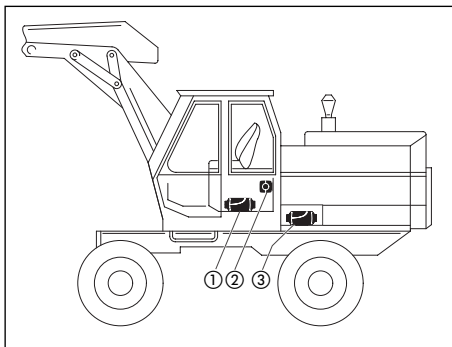

- ① Heater in the seat box
- ② Heater on the cab rear wall
- ③ Heater in a protective case

##### Installation in a truck (only diesel heaters)

In a truck, the heater is preferably installed inside the driver's cab. If it is not possible to install the heater inside the driver's cab, it can also be mounted in the tool box or in a storage box.

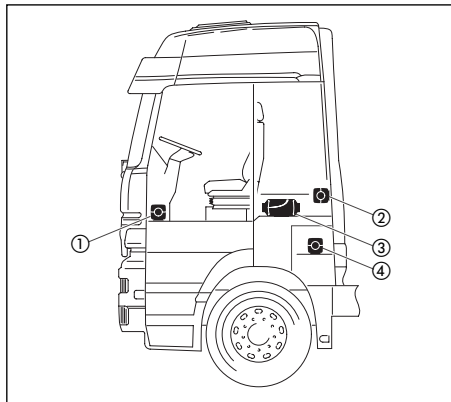

- ① Heater in the passenger's foot room
- ② Heater on the cab rear wall
- ③ Heater under the bed
- ④ Heater in the tool box

#### Please note!

- The installation suggestions made in the installation instructions are just examples. Other installation locations are possible, as long as they correspond to the installation requirements stated in these instructions.
- Other installation information (e.g. for boats and ships) is available from the manufacturer on request.
- Observe the tolerable installation position together with the operating and storage temperatures.

## 3 Installation

### Possible installation positions

The heater is preferably installed in the normal position as shown in the drawing. Depending on the installation conditions, the heater can be tilted by max. 30° (flow direction to the bottom) or turned by max. 90° around its own longitudinal axis (exhaust connection horizontal, glow plug points upwards!).

In the heating mode, the heater can deviate from the shown normal or maximum installation positions by up to +15° in all directions because of a slanting position of the vehicle or boat, without any impaired functions.

### Normal position horizontal (exhaust connection downwards) with tolerable swivel range

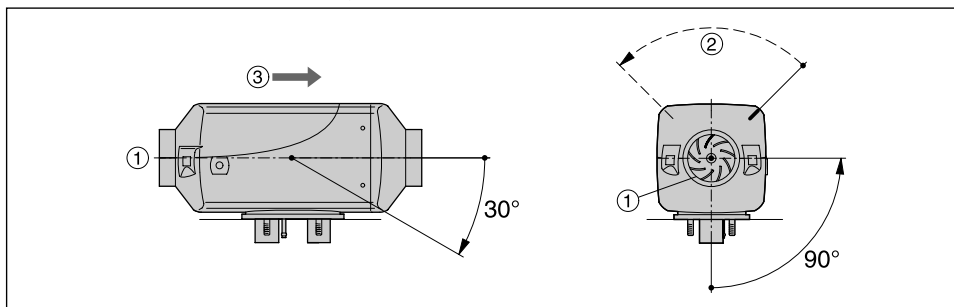

- ① Heater air intake opening (fan wheel)
- ② Position of the glow plus
- ③ Direction of flow

### Cable harness connection, right or left

If necessary, the cable harness connection can be changed over to the other side of the heater. To do so, the controller has to be removed and the lower semi-circular cable harness cover unclipped.

The cable harness can then be rerouted in the controller.

Then mount the controller again, position the jacket shell and insert the cable harness bush and the bungs in the corresponding recesses in the lower jacket shell.

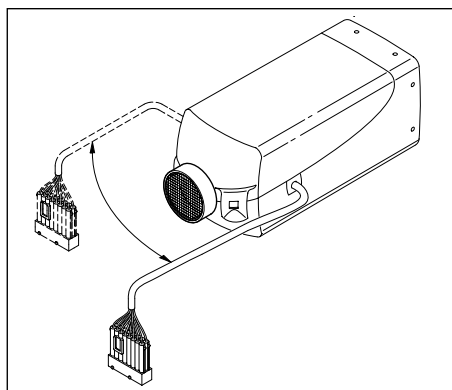

### 3 Installation

#### Mounting and fastening

Make the necessary breakthroughs for exhaust, combustion air and fuel as shown in the hole diagram. The support surface for the heater foot must be flat. An appropriate tool can be purchased from the manufacturer for drilling the breakthroughs and also smoothing the support surface.

The hole  $\varnothing$  10.5 mm for the cable harness "dosing pump" is not included in the picture drawing and must be drilled after installation.

If the sheet metal of the support surface is thinner

than 1.5 mm, an additional reinforcement plate will have to be fitted.

Order no: reinforcement plate 20 1577 89 00 03

Order no: special tool 99 1201 46 53 29

#### Picture hole

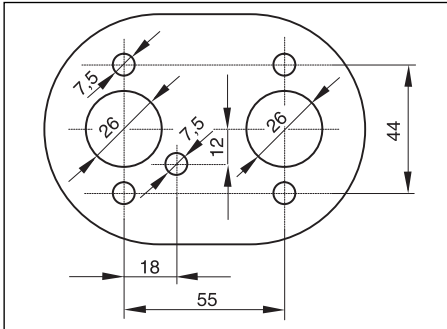

#### Special tool

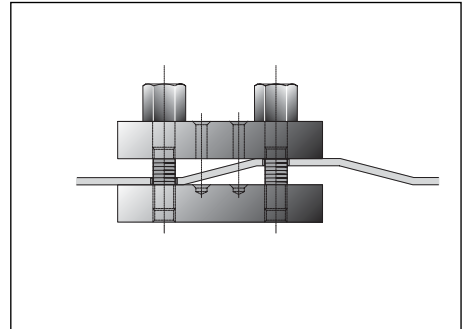

#### Fastening the unit on the vehicle floor

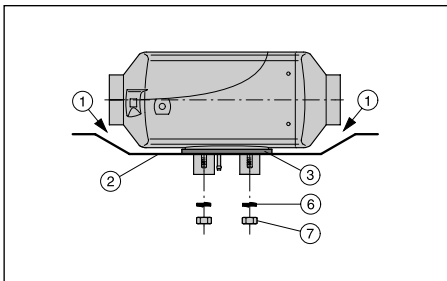

#### Fastening the heater horizontally to the vehicle wall

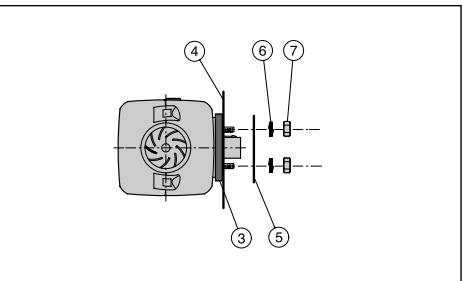

- ① There must be sufficient clearance between the heater and the vehicle floor – also check that the fan wheel runs freely.
- ② The mounting surface must be flat and smooth.
- ③ The flange seal must be mounted.

- ④ The vehicle wall must be flat and smooth.
- ⑤ Reinforcement plate (if required, see above)
- ⑥ Spring washer
- ⑦ Hexagon nut M6 (torque  $5^{+1}$  Nm)

### 3 Installation

#### Nameplate

The nameplate is fastened to the front of the heater. The second nameplate (duplicate) is included in the scope of supply of the heater.

If required, the duplicate nameplate can be adhered in a clearly visible position on the heater or near to the heater.

**Please note!**

The regulations and safety instructions to be observed for this chapter are stated on page 5.

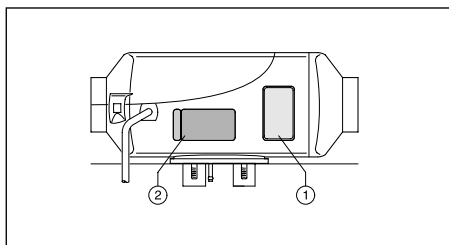

- ① Original nameplate
- ② 2<sup>nd</sup> nameplate (duplicate)



## 3 Installation

### Heater air system

The universal installation kit includes a flexible pipe, an outflow and a safety grid for the heater air system. The flexible pipe is not included in the installation kits for the camper heaters. It has to be ordered separately. The order number is stated in the Accessories Catalogue.



#### **Danger!**

#### **Risk of burning and injuries!**

- The hoses of the heater air system and the hot air outlet are to be routed and fastened in such a way that they pose no temperature risk to people, animals or materials sensitive to temperature from radiation / contact or blowing directly. If necessary, a cover is to be fitted to the heater air system or hot air outlet.
- The outflow hood must be fitted on the hot air outflow side.
- A safety grid must be fitted to the heater air intake side and outflow side if no air hoses are mounted, to prevent any injuries from the heater air fan or burns from the heat exchanger.
- High temperatures occur in the heater air system during and after the heater has been working. This is why it is important to avoid working in the vicinity of the heater air system while the heater is working. In such cases, switch the heater off beforehand and wait until all parts have cooled down completely. If necessary, wear safety gloves.

#### **Please note!**

- The regulations and safety instructions to be observed for this chapter are on page 4 – 7.
- Note the equipment code in the technical data (page 12 – 14) when connecting up airconveying parts.

### Heater air system (example)

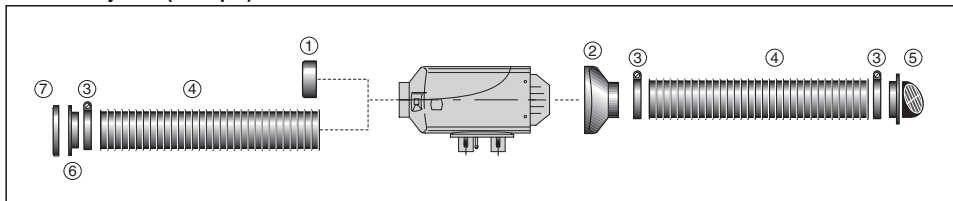

- |                 |                      |
|-----------------|----------------------|
| ① Safety grid   | ⑤ Rotating outflow   |
| ② Outflow hood  | ⑥ Connection fitting |
| ③ Hose clip     | ⑦ Safety grid        |
| ④ Flexible hose |                      |



#### **Caution!**

- The heater air intake openings must be arranged in such a way that under normal circumstances, it is not possible for exhaust from the vehicle engine and heater to be sucked into the system, or for the heating air to be contaminated with dust, salt spray, etc.
- For circulating air, position the circulating air intake in such a way that the outflowing hot air cannot be directly sucked in again.
- In the event of possible overheating, it is possible for local hot air temperatures of up to max. 150 °C or surface temperatures of up to max. 90 °C to occur immediately before the defect shutdown. Therefore only temperature-resistant hot air hoses approved by us must be used for the heater air system!
- When checking the functions, the mean outflow temperature measured after the heater has been running about 10 minutes at approx. 30 cm from the outlet should not exceed 110 °C (at an intake temperature of approx. 20 °C).
- If there is a risk of the driver and passengers touching the heater when the vehicle is being driven normally, a contact protection device must be fitted.

## 3 Installation

### Exhaust system

#### Mounting the exhaust system

The universal installation kit includes a flexible exhaust pipe, inner Ø 24 mm, 1000 mm long and an exhaust silencer. The flexible exhaust pipe can be shortened to 20 cm or lengthened to max. 2 m, depending on the installation conditions.

Fasten the exhaust silencer to a suitable position in the vehicle.

Route the flexible exhaust pipe from the heater to the exhaust silencer and fasten with pipe clips.

Connect an exhaust end pipe to the exhaust silencer and fasten with a pipe clip.

After finishing all installation work, place an end sleeve on the exhaust end pipe (Exhaust diagram see page 23).



#### Caution!

##### Safety instructions!

The whole exhaust system gets very hot during and immediately after the heater has been working. This is the reason why the exhaust system must be installed according to these instructions.

- The exhaust outlet must end in the open air.
- The exhaust pipe must not protrude beyond the lateral limits of the vehicle.
- Install the exhaust pipe sloping slightly downwards. If necessary, make a drain hole approx. Ø 5 mm at the lowest point to drain off condensation.
- Important functional parts of the vehicle must not be impaired (keep sufficient clearance).
- Mount the exhaust pipe with sufficient clearance to heat-sensitive parts. Pay particular attention to fuel pipes (plastic or metal), electrical cables and brake hoses etc.!
- Exhaust pipes must be fastened safely (recommended clearance of 50 cm) to avoid damage from vibrations.
- Route the exhaust system so that the emitted fumes are not sucked in with the combustion air.
- The mouth of the exhaust pipe must not get clogged by dirt and snow.
- The mouth of the exhaust pipe must not point in the direction of travel.
- Always fasten the exhaust silencer to the vehicle.



#### Danger!

##### Risk of injuries and burns!

Every type of combustion produces high temperatures and toxic exhaust fumes. This is the reason why the exhaust system must be installed according to these instructions.

- Do not perform any work on the exhaust system while the heater is working.
- Before working on the exhaust system, first switch the heater off and wait until all parts have cooled down completely, wear safety gloves if necessary.
- Do not inhale exhaust fumes.

#### Please note!

- Comply with the regulations and safety instructions for this chapter on page 4 – 7.
- If a silencer is fitted, the exhaust end pipe must be much shorter than the flexible exhaust pipe between the heater and the exhaust silencer.
- Small arrows indicating the direction of flow have been cast into the fittings to differentiate between the combustion air and the exhaust fittings at the heater (see diagram page 23).



### 3 Installation

#### Combustion air system

##### Mounting the combustion air system

The universal installation kit includes a flexible combustion air hose, inner  $\varnothing$  25 mm, 100 mm long. If necessary the flexible combustion air hose can be shortened by 20 cm or lengthened by max. 2 m depending on the installation conditions. Fasten the combustion air hose to the heater with a pipe clip and at suitable points with hose clips or cable ties.

The installation kit for camper heaters includes a combustion air intake silencer with a flexible connection hose (inner diameter 25 mm). Fasten the flexible connection hose to the heater with a pipe clip and fasten the combustion air intake silencer with hose clips or cable ties at suitable points.

After finishing the work, put an end sleeve on the combustion air hose or combustion air silencer.



#### Caution!

##### Safety instructions for the combustion air system!

- The combustion air opening must be free at all times.
- Position the combustion air intake to be sure that exhaust fumes cannot be sucked in with the combustion air.
- Do not arrange the combustion air intake to pointing against the wind blast.
- The combustion air intake must not get clogged with dirt and snow.
- Install the combustion air intake system sloping slightly downwards. If necessary, make a drain hole approx.  $\varnothing$  5 mm at the lowest point to drain off condensation.

#### Please note!

- For *AIRTRONIC* and *AIRTRONIC M* heaters a combustion air intake silencer can be fitted instead of the combustion air hose to reduce the noise level. The order number is stated in the Accessories Catalogue.
- Comply with the regulations and safety instructions for this chapter on page 4 – 7.

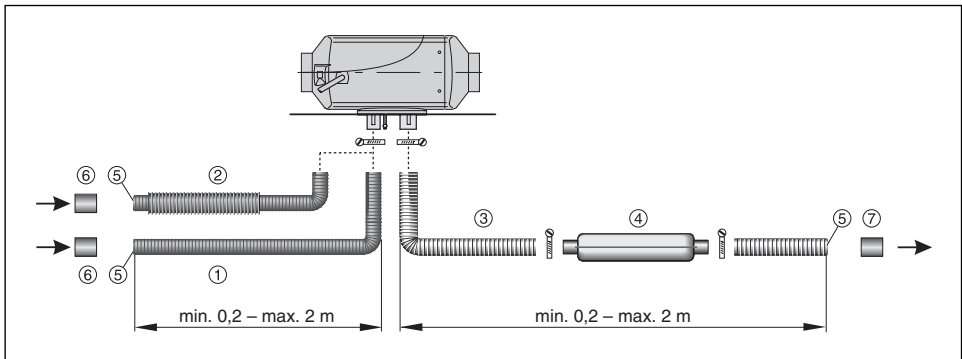

- ① Combustion air hose, di = 25 mm
- ② Combustion air silencer,
  - included in scope of supply for *AIRTRONIC* camper heaters
  - optional (not included in scope of supply for *AIRTRONIC* and *AIRTRONIC M* heaters)
- ③ Exhaust pipe, de = 24 mm
- ④ Exhaust silencer
- ⑤ Intake/outlet opening – protect from wind, snow, dirt and water.
- ⑥ End sleeve, combustion air
- ⑦ End sleeve, exhaust
- ⑧ Combustion air connection
- ⑨ Exhaust connection

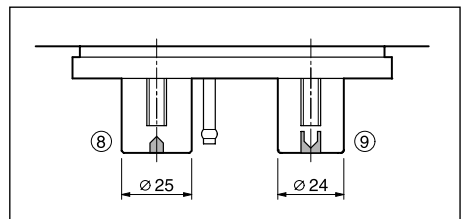

## 3 Installation

### Fuel supply

#### Mounting the dosing pump, routing the fuel pipes and mounting the fuel tank

The following safety instructions must be observed when mounting the dosing pump, routing the fuel pipes and mounting the fuel tank.

Deviations from the instructions stated here are not allowed.

Failure to comply can result in malfunctions.



#### **Danger!**

#### **Risk of fire, explosion, poisoning and injuries!**

Caution when handling fuel.

- Switch off the vehicle engine and heater before refuelling and before working on the fuel supply.
- No naked lights when handling fuel.
- Do not smoke.
- Do not inhale petrol fumes.
- Avoid any contact with the skin.



#### **Caution!**

#### **Safety instructions for routing the fuel pipes!**

- Only use a sharp knife to cut off fuel hoses and pipes. Interfaces must not be crushed and must be free of burrs.
- The fuel pipe from the dosing pump to the heater should be routed at a continuous rise.
- Fuel pipes must be fastened safely to avoid any damage and/or noise production from vibrations (recommended clearance of approx. 50 cm).
- Fuel pipes must be protected from any mechanical damage.

- Route the fuel pipes so that any distortion of the vehicle, engine movements etc. cannot have any lasting effect on the service life.
- Parts carrying fuel must be protected from interfering heat.
- Never route or fasten the fuel pipes to the heater or vehicle exhaust system. When the systems cross, always ensure there is a sufficient heat clearance. If necessary, install heat deflection plates.
- Dripping or evaporating fuel must never be allowed to collect on hot parts or ignite on electric systems.
- When connecting fuel pipes with a fuel hose, always mount the fuel pipes in a butt joint to prevent any bubbles from forming.

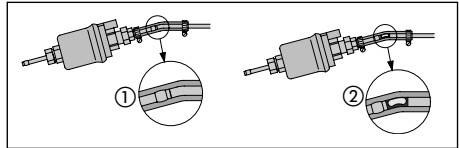

- ① Correct connection  
② Incorrect connection – bubble formation

#### **Safety instructions for fuel pipes and fuel tanks in buses and coaches**

- In buses and coaches, fuel pipes and fuel tanks must not be routed through the passenger compartment or driver's cab.
- Fuel tanks in buses and coaches must be positioned in such a way that the exits are not in direct danger from a possible fire.

#### **Please note!**

Comply with the regulations and safety instructions for this chapter on page 4 – 7.



### 3 Installation

#### Fuel supply

#### Fuel feed point with T-piece from the fuel supply line from the tank fitting to the vehicle engine

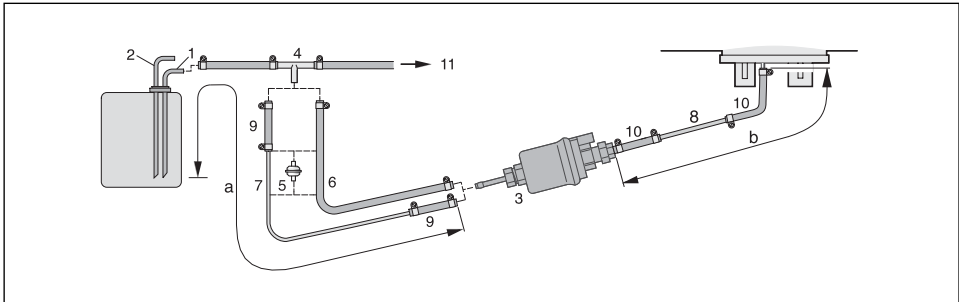

- ① Fuel feed pipe from tank connection
- ② Fuel return pipe to the tank connection
- ③ Dosing pump
- ④ T-piece, 8 - 6
- ⑤ Fuel filter – only necessary for contaminated fuel.
- ⑥ Fuel hose, 5 x 3 (di = Ø 5 mm)
- ⑦ Fuel pipe, 6 x 2 (di = Ø 2 mm)
- ⑧ Fuel pipe, 4 x 1.25 (di = Ø 1.5 mm)
- ⑨ Fuel hose, 5 x 3 (di = Ø 5 mm), approx. 50 mm long
- ⑩ Fuel hose, 3,5 x 3 (di = Ø 3.5 mm), approx. 50 mm long
- ⑪ To the engine, mechanical fuel or injection pump.

#### Possible pipe lengths

##### Intake side

*AIRTRONIC*  
a = max. 5 m

*AIRTRONIC M*  
a = max. 2 m

##### Pressure side

Diesel heaters

- For suction pipe di = Ø 2 mm, b = max. 6 m
- For suction pipe di = Ø 5 mm, b = max. 10 m

Petrol heater  
b = max. 4 m

#### Please note!

Insert the T-piece ④ before the feed pump in the fuel feed pipe.

Item ⑤ is not included in the scope of supply "installation kit".

Order no. see extra parts catalogue.

#### Installation position of the T-piece

Use the installation positions shown in the diagram when inserting a T-piece.

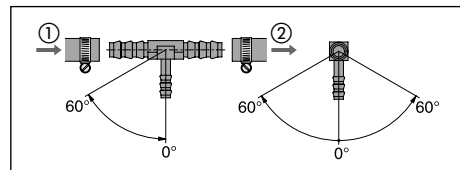

- ① Direction of flow from the fuel tank
- ② Direction of flow to the vehicle engine

### 3 Installation

#### Fuel supply

#### Fuel feed point with tank connection – ascending pipe, integrated in the vehicle tank or in the tank fitting

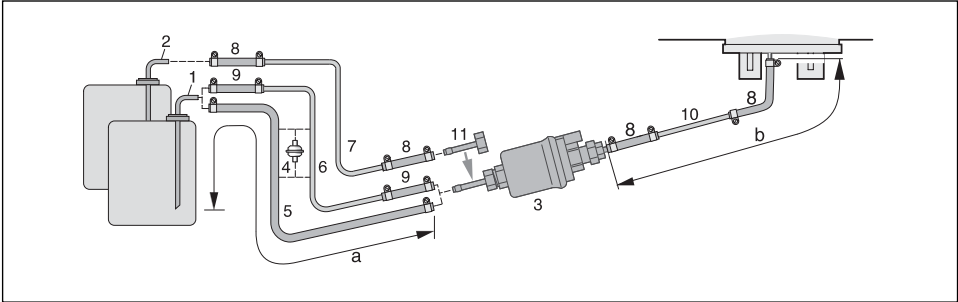

- ① Tank connection for metal tank –  
di = Ø 2 mm, da = Ø 6 mm
- ② Tank connection for tank fitting –  
di = Ø 2 mm, da = Ø 4 mm
- ③ dosing pump
- ④ Fuel filter – only required for contaminated fuel.
- ⑤ Fuel hose, 5 x 3 (di = Ø 5 mm)
- ⑥ Fuel pipe, 6 x 2 (di = Ø 2 mm)
- ⑦ Fuel hose, 4 x 1 (di = Ø 2 mm),
- ⑧ Fuel hose, 3,5 x 3 (di = Ø 3,5 mm),  
approx. 50 mm long
- ⑨ Fuel hose, 5 x 3 (di = Ø 5 mm),  
approx. 50 mm long
- ⑩ Fuel pipe, 4 x 1,25 (di = Ø 1,5 mm)
- ⑪ Connection fitting, da = Ø 4 mm

#### Possible pipe lengths

##### Intake side

*AIRTRONIC*  
a = max. 5 m

*AIRTRONIC M*  
a = max. 2 m

##### Pressure side

Diesel heaters  
• For suction pipe di = Ø 2 mm,  
b = max. 6 m

• For suction pipe di = Ø 5 mm,  
b = max. 10 m

Petrol heater  
b = max. 4 m

#### Please note!

Items ② ⑦ ⑪ are not included in the scope of supply "installation kit".



#### Caution!

#### Safety instructions for the fuel supply!

- The fuel must not be conveyed by gravity or overpressure in the fuel tank.
- Withdrawal of fuel after the vehicle's fuel pump is not allowed.
- When the pressure in the fuel pipe is more than 0.2 bar to max. 2 bar, use a pressure reducer (order no. 22 1000 20 09 00) or separate tank connection.
- When the pressure in the fuel pipe is more than 2 bar or there is a non-return valve in the return pipe (in the tank), a separate tank connection must be used.
- When using a T-piece in a plastic pipe, always use support sleeves in the plastic. Connect the T-piece and the plastic pipe with corresponding fuel hoses and secure with hose clips.

### 3 Installation

#### Fuel supply

##### Installation position of the dosing pump

Always mount the dosing pump with the pressure side rising upwards. Every installation position over 15° is allowed, although an installation position between 15° and 35° is preferable.

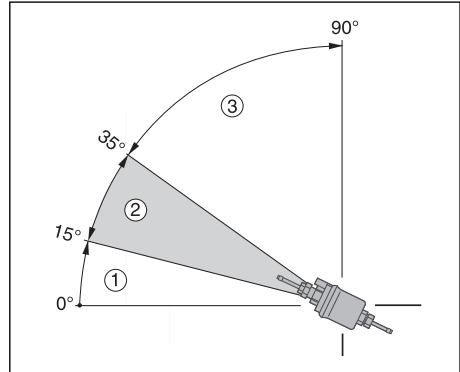

- ① Installation position between 0° and 15° is not allowed.
- ② Preferred installation position in range 15° to 35°.
- ③ Installation position in range 35° to 90° is allowed.

##### Possible suction and pressure height of the dosing pump

Pressure height from vehicle tank to dosing pump:  
a = max. 3000 mm

Intake height in pressure-less vehicle tank:  
b = max. 1000 mm for diesel  
b = max. 500 mm for petrol

Intake height in vehicle tanks with withdrawal by negative pressure (valve with 0.03 bar in tank cap):  
b = max. 400 mm

Pressure height of the dosing pump to the heater:  
c = max. 2000 mm

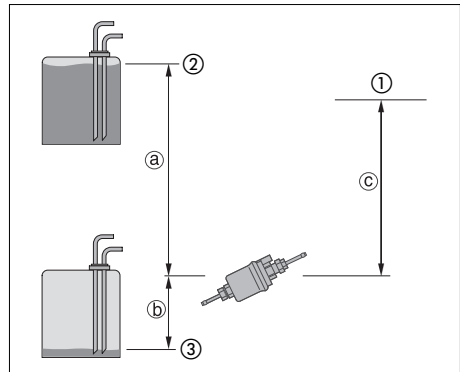

- ① Connection to heater
- ② Max. fuel level
- ③ Min. fuel level

**Please note!**

Check tank venting.



**Caution!**

**Safety instructions for installing the dosing pump**

- Always mount the dosing pipe with the pressure side rising upwards – minimum incline 15°.
- Protect the dosing pump and filter from intolerable heat, do not mount near to the silencers and exhaust pipes.

## 3 Installation

### Fuel supply

#### Fuel quality for petrol heaters

The heater runs smoothly on standard commercial quality petrol in accordance with DIN EN 228, which you use to run your vehicle engine.

#### Fuel quality for diesel heaters

The heater runs smoothly on standard commercial quality diesel in accordance with DIN EN 590, which you use to run your vehicle engine.

#### Fuel for special cases

In special cases (above 0 °C), the heater can also run on fuel oil EL or paraffin.

#### Fuel for low temperatures

Refineries and fuel service stations automatically adjust the fuel to normal winter temperatures (winter diesel). This means that difficulties are only to be expected for extreme drops in temperature, as also apply to the vehicle engine. Please also refer to the vehicle manual.

If the heater is run from a separate tank, please comply with the following rules:  
For temperatures above 0 °C, any kind of diesel fuel as per DIN EN 590 can be used.

If no special diesel fuel is available for low temperatures, then paraffin or petrol should be mixed with the fuel according to the following table:

Temperature	Winterdiesel	Addition
0 °C to -25 °C	100%	---
-25 °C to -40 °C	50%*	50% paraffin or petrol

\* or 100% special cold diesel fuel (Arctic diesel)

#### Please note!

- Mixtures with used oil are not allowed!
- After refuelling with winter or cold diesel or the listed blends, the fuel pipes and the dosing pump must be filled with the new fuel by letting the heater run for 15 mins.!

#### Operation with biodiesel (PME)

##### **AIRTRONIC**

The heater is **not** certified for operation with biodiesel. Biodiesel can be added to the fuel to up to 10%.

##### **AIRTRONICM**

The diesel heaters are certified for operation with biodiesel as per DIN V 51606 in a free-flowing state up to -8 °C.

#### Please note!

- When using 100% biodiesel, the heater should be operated twice a year with diesel fuel (in the middle and at the end of a heating period) to burn off any possible PME deposits.  
To do so, let the vehicle tank run almost empty and fill with diesel fuel without adding any biodiesel. While running on this tank filling, switch the heater on 2 to 3 times for 30 minutes at a time at the highest temperature setting.
- When operating with diesel/biodiesel mixtures of up to 50% biodiesel, intermediate operation with pure diesel fuel is not necessary.



## 4 Operation and function

### Operating instructions

The heater is operated by a control unit. The control unit is accompanied by detailed operating instructions which you will receive from the company installing the heater.

#### **Please note!**

The control elements (e.g. mini timer, module timer) are accompanied by detailed operating instructions which you will receive from the company installing the heater.

### Important instructions for operation

#### **Safety checks before the start**

After a longer interval in operations (after the summer months) the fuse must be put in position and/or the heater connected up to the battery. Check that all parts fit firmly (tighten screws where necessary). Check the fuel system visually for any leaks.

#### **Heating at high altitudes**

When using the heater at high altitudes, please note:

- Heating at altitudes up to 1500 m:
  - Unlimited heating possible.
- Heating at altitudes over 1500 mm:
  - Heating is possible for short periods at this altitude (e.g. driving over a mountain pass or taking a break in a journey).
  - Heating is not possible for longer periods at this altitude (e.g. winter camping).

### Initial commissioning

The following points are to be checked by the company installing the heater during initial commissioning.

- After installation of the heater, the coolant circuit and the whole fuel supply system must be vented carefully. Comply with the instructions issued by the vehicle manufacturer.
- During the trial run of the heater, check all water and fuel connections for leaks and firm fitting.
- If the heater shows a fault during operation, find and eliminate the cause of the fault using a diagnosis unit.

## 4 Operation and function

### Description of functions

#### Switching on

When the heater is switched on, the control lamp in the control element lights up.

The glow plug is switched on and the fan starts at low speed.

#### Please note!

If there is still too much residual heat in the heat exchanger from when the heater was last used, firstly only the fan starts up (cold blowing).

Once the residual heat has been cleared, the heater starts.

#### Starting *AIRTRONIC*

After approx. 60 seconds the fuel supply starts and the fuel/air mixture in the combustion chamber ignites. Once the combined sensor (flame sensor) has detected the flame, the glow plug is switched off after 60 seconds.

After another 120 seconds, the heater has reached the "POWER" stage (maximum fuel quantity, maximum fan speed).

#### Starting *AIRTRONIC M*

After approx. 60 seconds the fuel supply starts and the fuel/air mixture in the combustion chamber ignites. Once the combined sensor (flame sensor) has detected the flame, the glow plug is switched off after approx. 80 seconds, the heater is in the normal mode.

#### Temperature selection with the control element

Select the required passenger compartment temperature with the knob. The temperature setting can be between +10 °C and +30 °C depending on the size of the room being heated and the prevailing outside temperature. The required setting of the knob is an empirical value.

#### Control in the heating mode

During the heating mode, the room temperature or the temperature of the sucked in heating air is constantly measured.

If the temperature is higher than the temperature selected on the control element, the heater starts to regulate its output. There are 4 control stages so that the outflow of heat produced by the heater can be adjusted finely to the heating requirements. Fan speed and fuel quantity correspond to the particular control stage.

If the set temperature is still exceeded in the smallest control stage, the heater goes to the "OFF" stage with the fan running on for approx. 4 minutes to cool off. Then the fan continues at minimum speed (circulation mode) or is switched off (fresh air mode) until the heater is started again.

#### Ventilating mode

In the ventilating mode, first the changeover switch "heating/venting" has to be activated and then the heater is switched on.

#### Switching off

When the heater is switched off, the control lamp goes off and the fuel supply is switched off. The fan runs on for approx. 4 minutes to cool down. While the fan is running on, the glow plug is switched on for approx. 40 seconds to clean.

Special case:

If no fuel has been supplied or if the heater is in the "OFF" stage until it is switched off, the heater is stopped without any after running.



## 4 Operation and function

### Control and safety devices

- If the heater does not ignite within 90 seconds after starting the fuel pump, the start is repeated. If the heater still does not ignite after another 90 seconds of pumping fuel, the heater is switched off, i.e. the fuel supply is off and the fan runs on for approx. 4 minutes.  
After an unacceptable number of failed start attempts, the controller is locked.\*

- If the flame goes off by itself during operation, the heater is restarted. If the heater does not ignite within 90 seconds after the fuel pump has started, or ignites and goes off again within 15 minutes, the heater is switched off, i.e. the fuel supply is off and the fan runs on for approx. 4 minutes.  
This status can be remedied by briefly switching off and on again.  
Do not repeat the switching off/on routine more than twice.

- In the case of overheating, the combined sensor (flame sensor/overheating sensor) triggers, the fuel supply is interrupted and the heater switched off. Once the cause of the overheating has been eliminated, the heater can be re-started by switching off and on again. After the heater has been switched off for overheating an unacceptable number of times, the controller is locked.\*

- If the lower or upper voltage limit is reached, the heater is switched off after 20 seconds.
- The heater does not start up when the glow plug is defect or when the electric lead to the dosing pump is interrupted.
- If the combined sensor (flame sensor / overheating sensor) is defect or the electric lead interrupted, the heater starts up and is then switched off again during the start phase.

- The speed of the fan motor is monitored continuously. If the fan motor does not start up or if the speed deviates by more than 10%, the heater is switched off after 30 sec.
- When the heater is switched off, the glow plug is switched on for 40 seconds (after-glowing) while the fan runs on to clean off any combustion residues.

\* The controller can be enabled again and the faults read off:

- using the module timer
- using the radio remote control TP5.

For other controls:

- by connecting up a diagnosis unit
- using the customer service program KD2000.

For operation and fault list, please refer to the enclosed operating instructions or the troubleshooting and repair instructions for the heater.

#### **Please note!**

Do not switch the heater off and on again more than twice.

#### **Forced shutdown in ADR / ADR99 mode (only for diesel heaters)**

In vehicles for the transport of dangerous goods (e.g. tanker trucks), the heater must be switched off before the truck drives into a danger area (refinery, fuel service station, etc.).

Failure to comply results in the heater switching off automatically when:

- The vehicle engine is switched off.
- An additional unit is started up (e.g. auxiliary drive for unloading pump etc.).
- A vehicle door is opened (ADR99 regulation, only in France).

The fan then runs on for max. 40 seconds.

#### **Emergency shutdown – EMERGENCY OFF**

If an emergency shutdown – EMERGENCY OFF – is necessary during operation, proceed as follows:

- Switch the heater off with the control or
- pull the fuse out or
- disconnect the heater from the battery.

## 5 Electrical system

### Heater wiring



#### Caution!

#### Safety instructions for wiring the heater!

The heater is to be connected up electrically according to the EMC directives.

EMC can be affected if the heater is not connected up correctly. For this reason, comply with the following instructions:

- Ensure that the insulation of electrical cables is not damaged. Avoid: chafing, kinking, jamming or exposure to heat.
- In waterproof connectors, seal any connector chambers not in use with filler plugs to ensure they are dirt-proof and water-proof.
- Electrical connections and ground connections must be free of corrosion and firmly connected.
- Lubricate connections and ground connections outside the heater interior with contact grease.

#### Please note!

Comply with the following when wiring the heater and the control element:

- Electrical leads, switchgear and controllers must be arranged in the vehicle so that they can function perfectly under normal operating conditions (e.g. heat exposure, moisture etc.).
- The following cable cross sections are to be used between the battery and heater. This ensures that the max. tolerable voltage loss in the cables does not exceed 0.5 V for 12 V or 1 V for 24 V rated voltage.  
  
Cable cross sections for a cable length of:  
– up to 5 m (plus cable + minus cable) = cable cross section 4 mm<sup>2</sup>  
– from 5 to 8 m (plus cable + minus cable) = cable cross section 6 mm<sup>2</sup>
- If the plus cable is to be connected to the fuse box (e.g. terminal 30), the vehicle cable from the battery to the fuse box must be included in rating the overall cable length and possibly re-dimensioned if necessary.
- Insulate unused cable ends.

### Parts list for the circuit diagrams *AIRTRONIC* and *AIRTRONIC M*

- |       |   |
|-------|---|
| 1.1   | Burner engine   |
| 1.2   | Glow plug   |
| 1.5   | Overheating and flame sensor  |
| 2.1   | Controller  |
| 2.2   | Dosing pump   |
| 2.7   | Main fuse<br>12 volt = 20 A<br>24 volt = 10 A                                   |
| 2.7.1 | Fuse, actuation 5A  |
| 5.1   | Battery   |
| 5.2.1 | Battery operation switch d)<br>(operation, e.g. controlled by the ignition key) |
| 5.2.2 | Battery separating switch d)<br>(Emergency off function for ADR / ADR99)        |
| 5.3   | Auxiliary drive HA+   |
| 5.3.1 | Switch, auxiliary drive   |
| 5.5   | Generator D+  |
- a) Connection of the control unit and external sensor according to the circuit diagram "control units"
- rt (red) Power supply, plus – terminal 30
  - ge (yellow) Switch-on signal – S+
  - gr (green) Actual temperature
  - wsrt (white/red) Switch off burglar alarm (ADR / ADR99 – feedback for timer)
  - br (brown) Power supply, minus – terminal 31
  - blws (blue/white) Diagnosis
  - grtt (green/red) Nominal temperature
  - brws (brown/white) Reference signal sensor
- b) Option
- Vehicle fan control and / or
  - separate fresh air fan
- c) Wiring for operation to ADR / ADR99 (HGV vehicle transporting dangerous goods, e.g. tanker truck)
- d) When only one switching element is used for item 5.2.1 and 5.2.2 it must be ensured that on activating the function "open the battery separating switch" (EMERGENCY OFF function for ADR / ADR99 etc.), the switch always separates immediately (regardless of the heater status) and all the heater circuits are disconnected from the battery.





## 5 Electrical system

### Parts list circuit diagrams control elements

- 2.15.1 Temperature sensor (room temperature)
- 2.15.9 Temperature sensor (outside temperature)
  
- 3.1.9 Changeover "heating/venting"
- 3.1.16 Button radio remote control
- 3.1.17 Mini controller *AIRTRONIC*
- 3.1.18 Button *CALLTRONIC*
- 3.2.8 Module timer (ADR / ADR99 potentiometer)
- 3.2.12 Timer, mini – 12 / 24 volt
- 3.2.14 Lighting, mini timer – 12 volt only
- 3.3.6 Radio remote control stationary part TP41i
- 3.3.7 Radio remote control stationary part TP5
- 3.3.8 Remote control *CALLTRONIC*
- 3.8.3 Antenna
- 3.9.1 Diagnosis, JE diagnosis

- a) Connection control elements to the *AIRTRONIC*
  - rt Power supply, plus – terminal 30
  - ge Switch-on signal – S+
  - gr Actual temperature
  - wsrt Switch off burglar alarm  
(ADR / ADR99 – feedback for timer)
  
  - br Power supply, minus – terminal 31
  - blws Diagnosis
  - grrt Nominal temperature
  - brws Ground connection for external  
temperature sensor and nominal  
temperature
- b) Terminal 15 – necessary for connecting TP4i
- c) Lighting, terminal 58
- d) Connection, diagnosis device
- e) Connection, external temperature sensor
- g) Connection, external heating button 
- h) Connection, radio remote control TP4i
- j) Connection, temperature sensor  
(outside temperature)
- l) Connection, change-over  
"heating / venting" (option)  
To start:  
Activate changeover "heating / venting"  
then switch *AIRTRONIC* on
- z) Lighting, terminal 58

### Cable colours

- rt = red
- bl = blue
- ws = white
- sw = black
- gn = green
- gr = grey
- ge = yellow
- vi = violet
- br = brown
- li = purple

### Please note!

The circuit diagrams are printed at the end of this manual.

Connectors and bush housings are shown.

## 6 Troubleshooting / Maintenance / Service

---

### In case of faults, please check the following points

- If the heater does not start after being switched on:
  - Switch the heater off and on again.
- If the heater still does not start, check whether:
  - There is fuel in the tank?
  - The fuses are OK?
  - The electrical cables, connections etc. are OK?
  - Anything is clogging the combustion air supply or exhaust system?

### Troubleshooting

If the heater remains faulty even after these points have been checked, or another malfunction occurs in your heater, please contact:

- For installation ex works, your contract workshop.
- For subsequent installation, the workshop who installed your heater.

#### **Please note!**

Please note that warranty claims can become void if the heater is changed by a third party or by this installation of third party parts.

### Maintenance instructions

- Switch the heater off once a month for about 10 minutes, even outside the heating period.
- Before the heating period starts, the heater should undergo a trial run.  
If persistent extreme smoke develops, unusual burning noises or a clear fuel smell can be perceived or if electric/electronic parts heat up, the heater must be switched off and put out of service by removing the fuse.  
In this case, the heater should not be started up again until it has been checked by qualified staff who have been trained on Eberspächer heaters.
- Check the openings of the combustion air supply and exhaust system after longer standstill periods, clean if necessary!

### Service

If you have any technical queries or problems with your pre-heater, dial the following service phone number:

Hotline  
Phone. 0800 / 12 34 300

Fax hotline  
Fax 01805 / 26 26 24



## 7 Environment

### Certification

The high quality of Eberspächer's products is the key to our success.

To guarantee this quality, we have organised all work processes in the company along the lines of quality management (QM).

Even so, we still pursue a large number of activities for continuous improvement of product quality in order to keep pace with the similarly constantly growing requirements made by our customers.

All the steps necessary for quality assurance are stipulated in international standards.

This quality is to be considered in a total sense.

It affects products, procedures and customer/supplier relationships.

Officially approved public experts assess the system and the corresponding certification company awards a certificate.

Eberspächer has already qualified for the following standards:

**Quality management as per  
DIN EN ISO 9001:2000 and ISO/TS 16949:1999**

**Environment management system as per  
DIN EN ISO 14001:1996**

### Disposal

#### Disposal of materials

Old devices, defect components and packaging material can all be separated and sorted into pure-grade fractions so that all parts can be disposed of as required in an environment-friendly manner or recycled where applicable.

Electric motors, controllers and sensors (e.g. temperature sensors) are deemed to be "electronic scrap".

#### Dismantling the heater

The heater is dismantled according to the repair stages in the current troubleshooting/repair instructions.

#### Packaging

The packaging of the heater can be kept in case it has to be sent back.

### EU Declaration of Conformity

With regard to the following products

#### heater type **AIRTRONIC / AIRTRONIC M**

we herewith confirm that it conforms with the prime safety requirements stipulated in the directives of the EU Council for harmonisation of the legal regulations of the member states with regard to electromagnetic compatibility (89 / 336 / EEC).

This declaration applies to all heaters produced according to the production drawings *AIRTRONIC / AIRTRONIC M*, which are an integral part of this declaration.

The following standards/directives have been used to assess the product with regard to electromagnetic compatibility:

- EN 50081 – 1 Basic form interference emission.
- EN 50082 – 1 Basic form interference resistance.
- 72 / 245 / EEC – Modification status 95 / 54 / EU interference suppression in motor vehicles.

## 8 Lists

### List of key words A – Z

<b>Keyword</b>	<b>Page</b>
<b>A</b>	
Accident prevention .....	7
ADR / ADR99 .....	16, 31
Altitude .....	29
Ambient temperature .....	12 – 14
<b>C</b>	
Cable harness connection .....	18
Certificates .....	35
Circuit diagrams (at the end of the manual)	
Combustion air system .....	23
Control devices .....	31
Control in heating mode .....	30
Contents .....	2
<b>D</b>	
Dangerous goods .....	16, 31
Declaration of conformity .....	35
Description of functions .....	30
Disposal .....	35
Dosing pump .....	24 – 27
<b>E</b>	
Electronic components .....	33, 33
Emergency off .....	31
Emergency stop .....	31
Environment protection .....	35
EU Declaration of Conformity .....	35
Extra parts .....	9
Exhaust .....	22
Exhaust system .....	22
<b>F</b>	
Faults .....	34
Fastening .....	19
Fan operation .....	30
Forced shut-down .....	31
Formation of air bubbles .....	24
Fuel .....	5, 24 – 28
Fuel withdrawal .....	24 – 26
Fuel system .....	24 – 28
Fuel quality .....	28
<b>H</b>	
Heat flow .....	12 – 14
Heating operation .....	29, 30
Heater air system .....	23
Hotline .....	34

<b>Keyword</b>	<b>Page</b>
<b>I</b>	
Instructions .....	4, 5
Installation .....	16 – 28
Installation area .....	16, 17
Interference suppression class .....	12 – 14
Initial commissioning .....	29
Installation location .....	16, 17
Installation position .....	18
Index .....	36, 37
Information .....	4
<b>L</b>	
Lists .....	36, 37
List of key words .....	36, 37
List of special terms .....	37
List of abbreviations .....	37
<b>M</b>	
Maintenance .....	34
Main dimensions .....	15
<b>N</b>	
Nameplate .....	20
Noise emission .....	12 – 14
<b>O</b>	
Operation .....	29
Operating instructions .....	29
<b>P</b>	
Picture symbols .....	4
Power consumption .....	12 – 14
Pressure height .....	27
Pressure side .....	25, 26
Presentation .....	4
Purpose .....	4
<b>R</b>	
Rated voltage .....	12 – 14
Regulations .....	5, 6
<b>S</b>	
Safety devices .....	31
Safety check (before starting) .....	29
Scope of supply .....	8 – 11
Storage temperature .....	12 – 14
Statutory regulations .....	5, 6
Start procedure .....	30
Suction height .....	27
Switching on .....	30
Switching off .....	30



## 8 Lists

### List of key words A – Z

<b>Keyword</b>	<b>Page</b>
<b>T</b>	
Technical data .....	12 – 14
Temperature selection .....	30
Test symbol .....	5
Text structure .....	4
T-piece .....	25
Transport .....	16
Troubleshooting .....	34
<b>U</b>	
Use .....	4
<b>V</b>	
Voltage .....	12 – 14
Voltage limit .....	12 – 14
<b>W</b>	
Weight .....	12 – 14
Wiring .....	32

### List of abbreviations

<b>ADR</b>	European agreement about the international transport of dangerous goods on the road.
<b>ADR99</b>	Dangerous goods regulations for France.
<b>EC Type approval</b>	Permit awarded by the Federal Vehicle Office for the production of a heater for installation in motorised vehicles.
<b>EMC directive</b>	Electromagnetic compatibility.
<b>JE partner</b>	J. Eberspächer partner.
<b>PME</b>	Biodiesel as per DIN V 51606.

**AIRTRONIC / AIRTRONIC M**

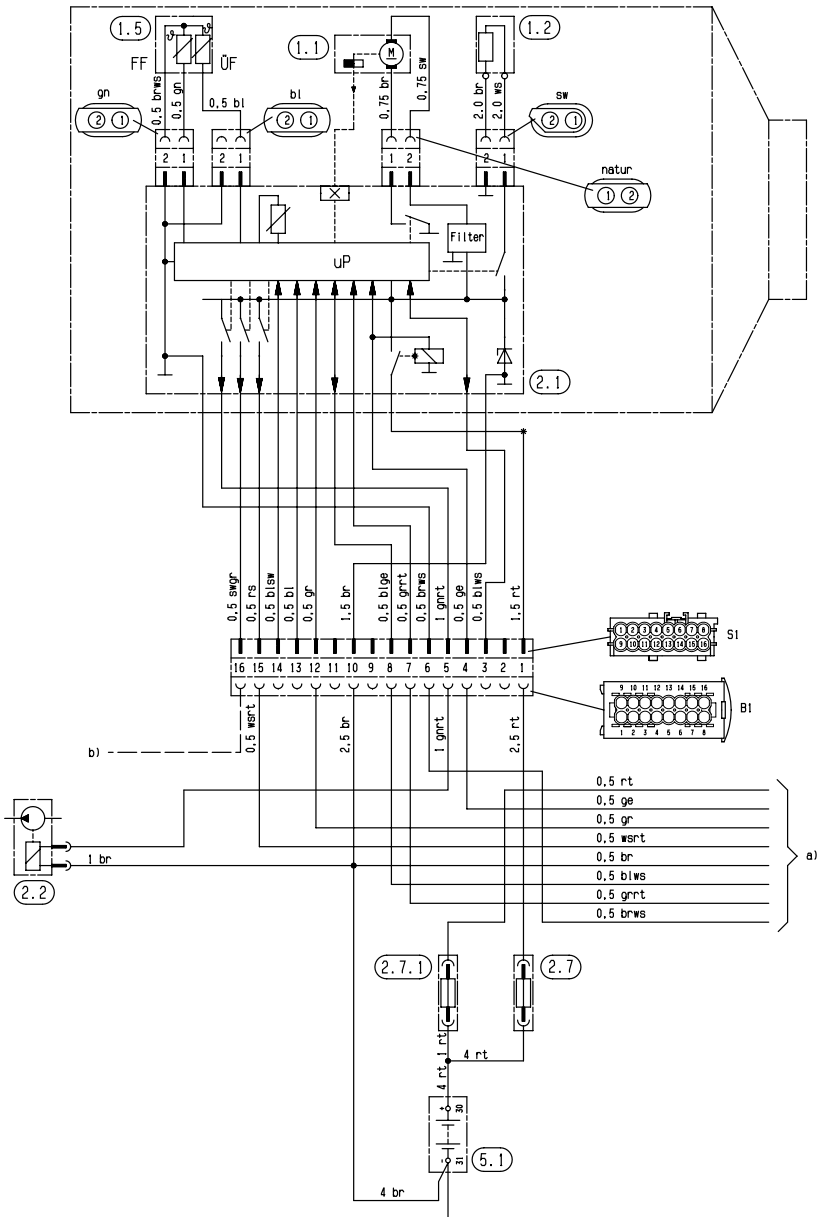

## Control elements Éléments de commande

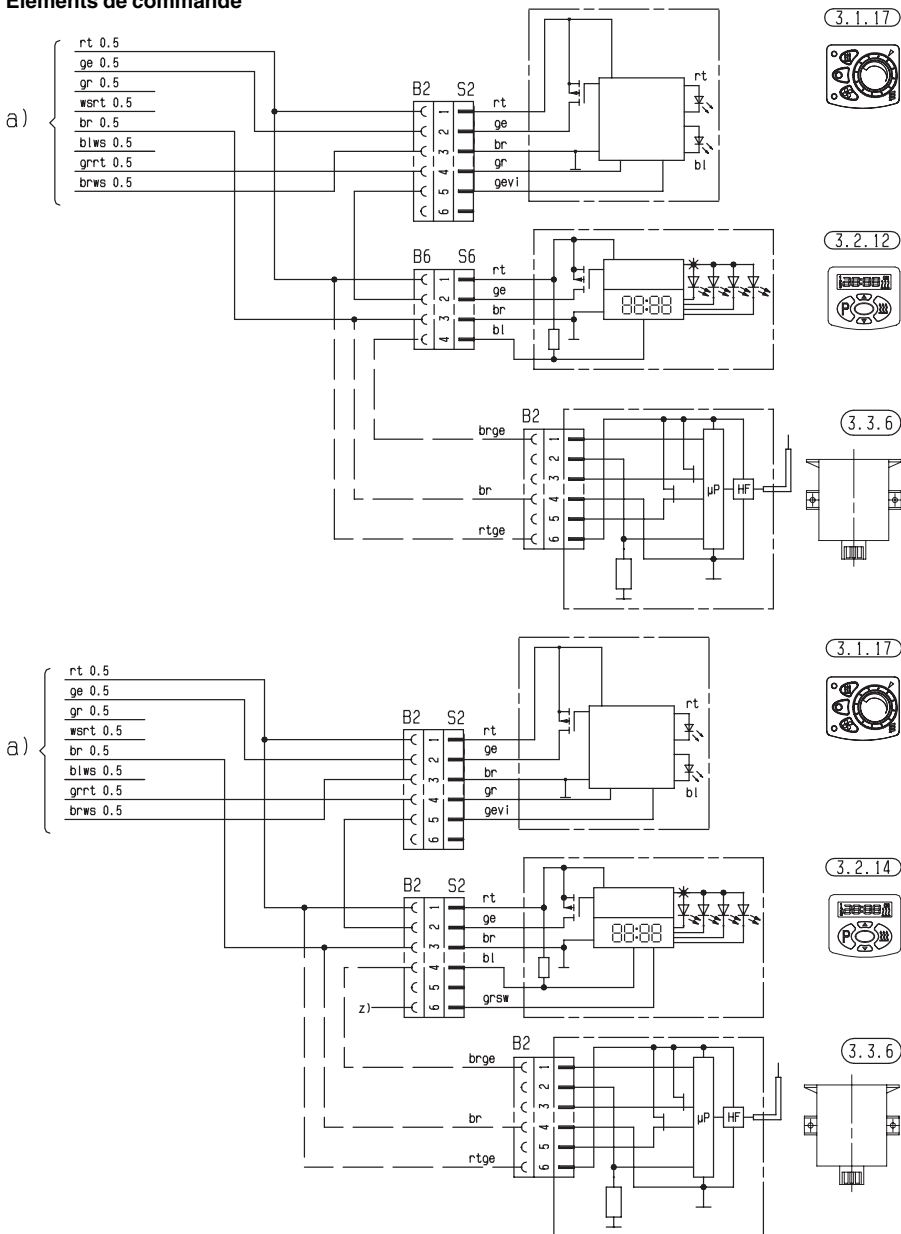



## Control elements Éléments de commande

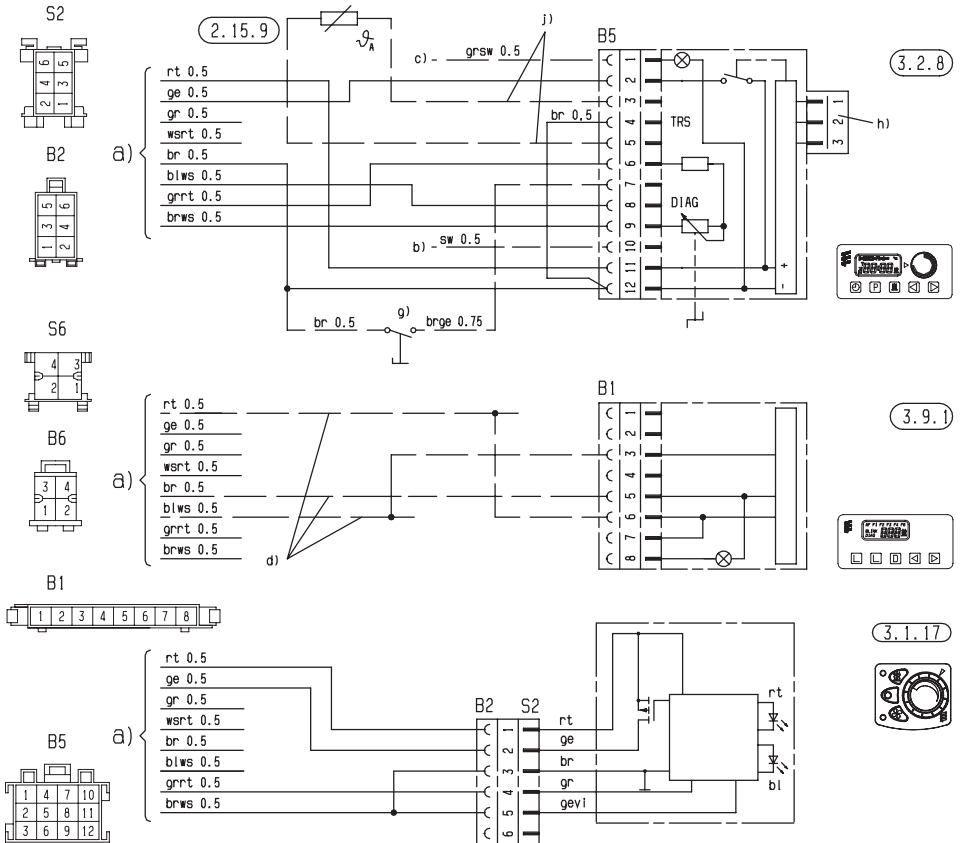



**Control elements**  
**Éléments de commande**

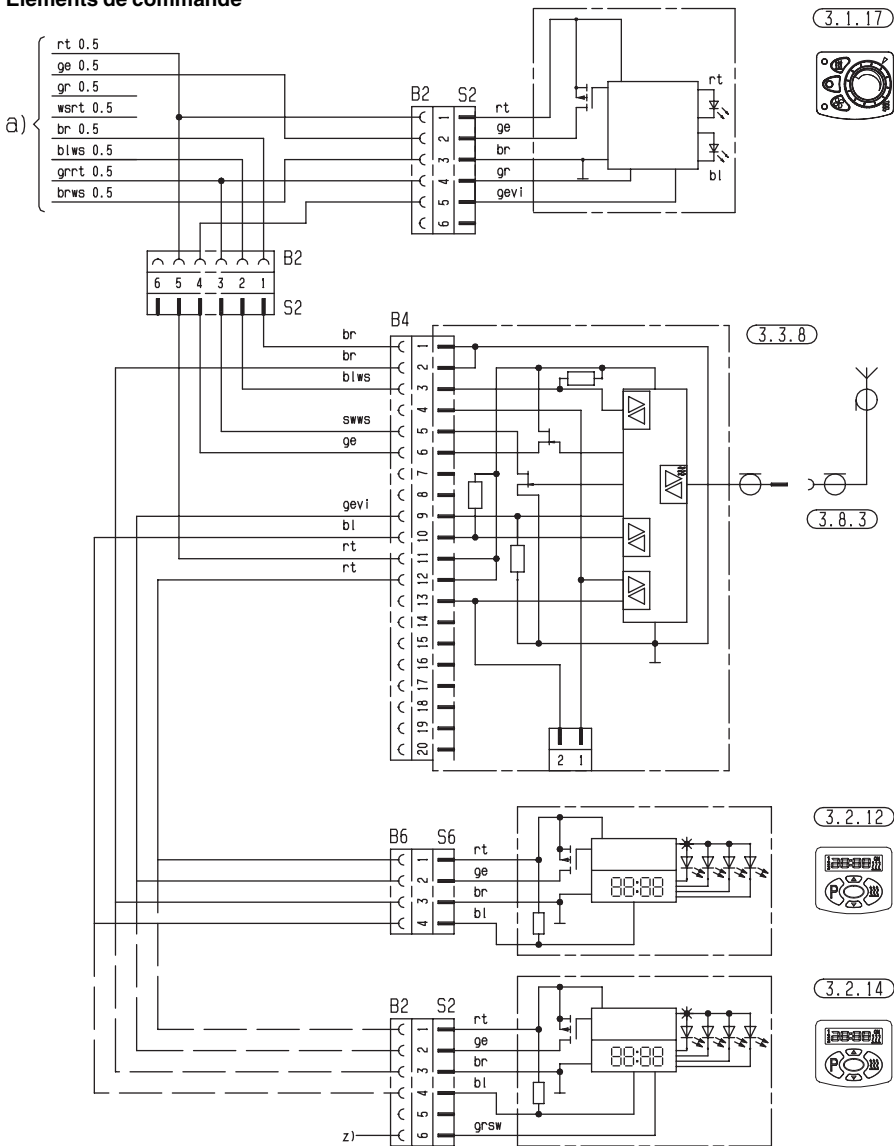

EN  
FR

**Control elements**  
**Éléments de commande**

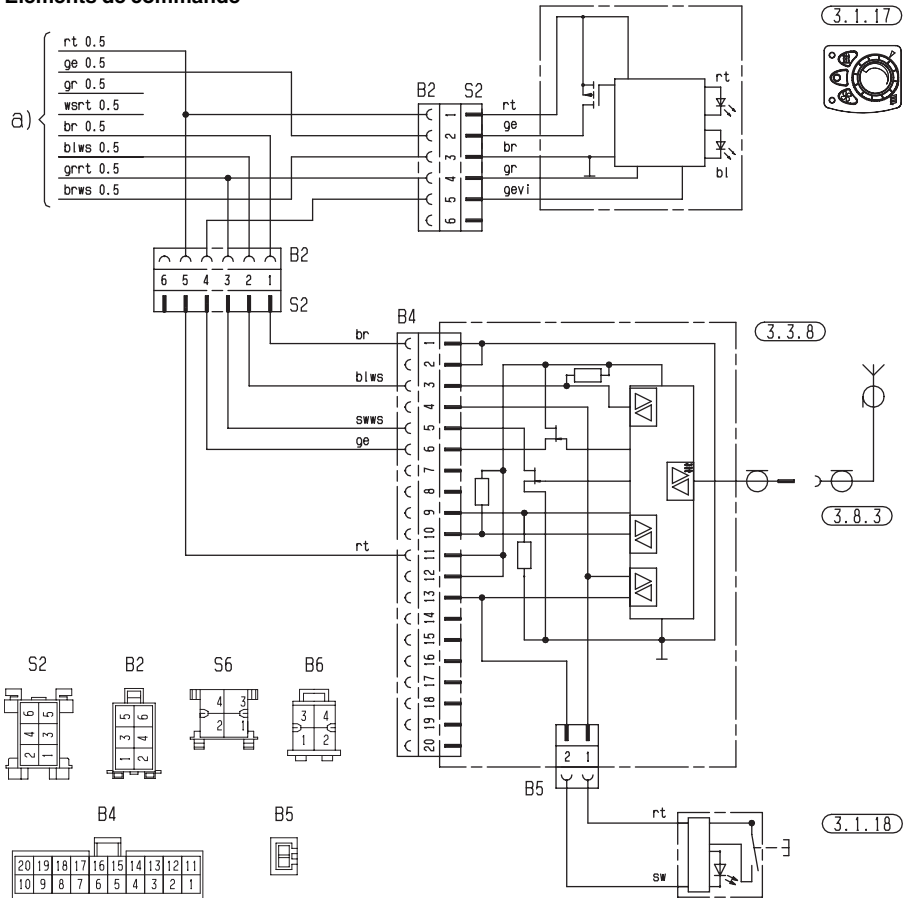

**Control elements**  
**Éléments de commande**

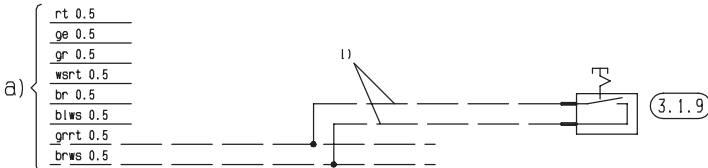
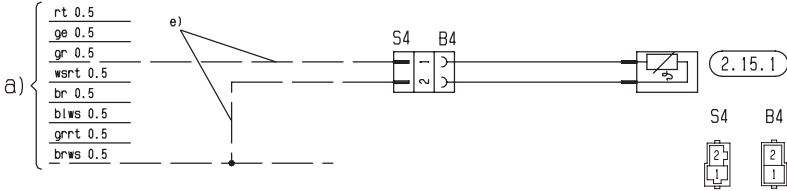

25 2069 00 97 01 C

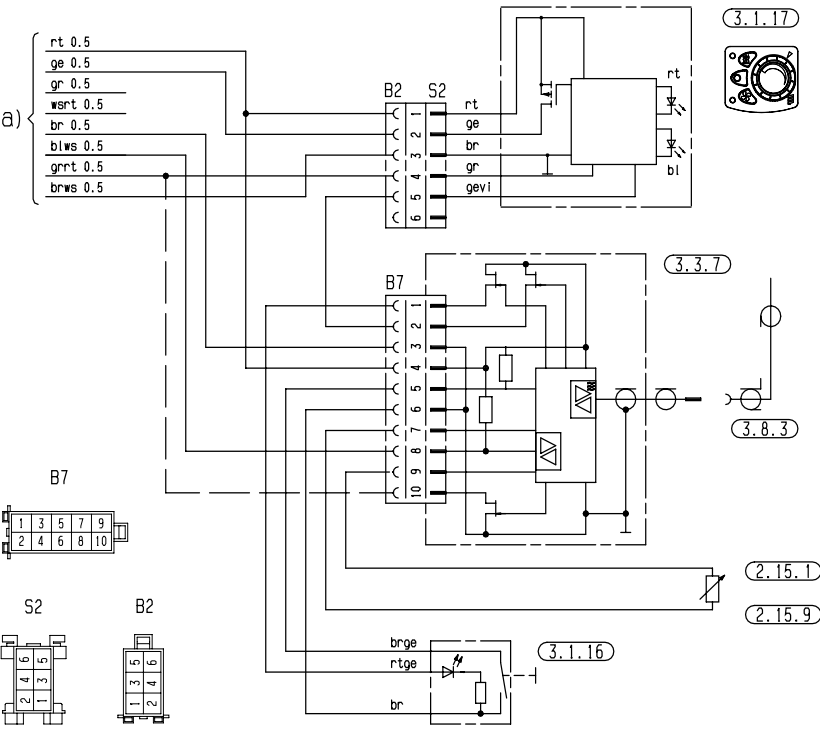

EN  
FR

**AIRTRONIC / AIRTRONIC M – ADR / ADR 99**

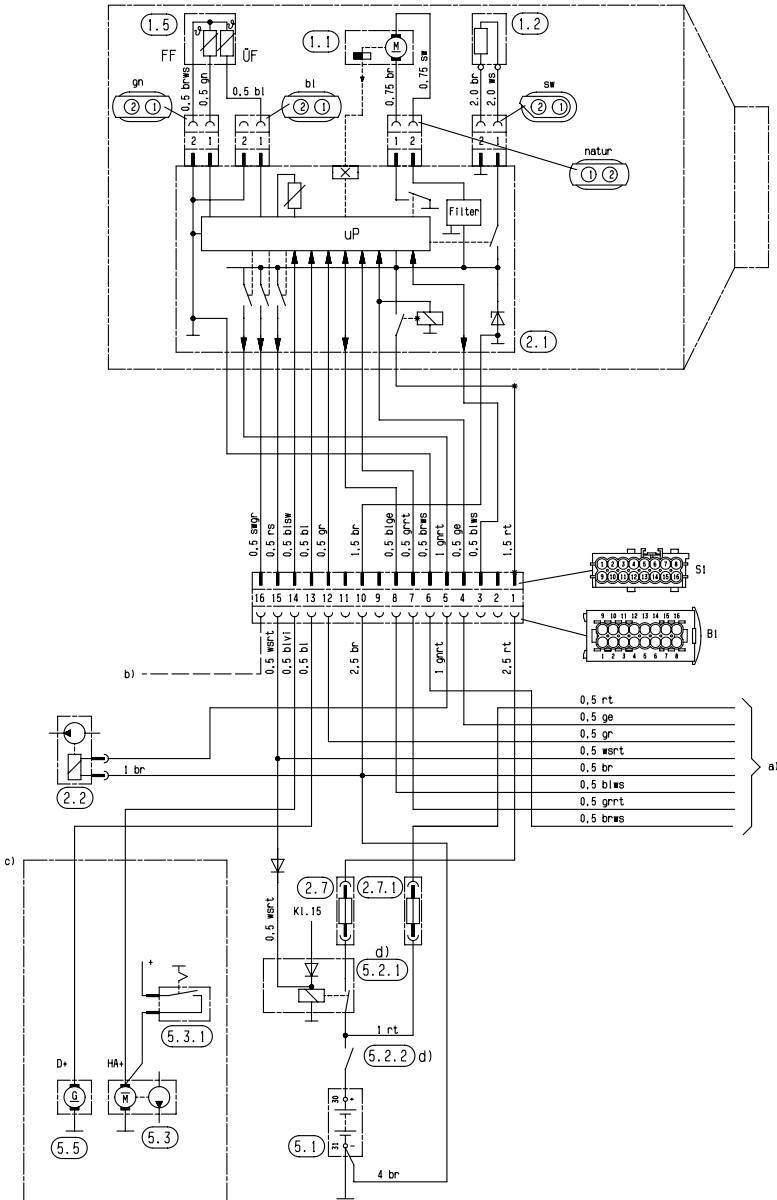

## Control elements – ADR / ADR 99 Éléments de commande – ADR / ADR 99

